

Installation

The versatility of the Origa rodless cylinder is demonstrated in a wide range of applications.

Proven technology, used worldwide in all areas where lifting and transfer operations are required.

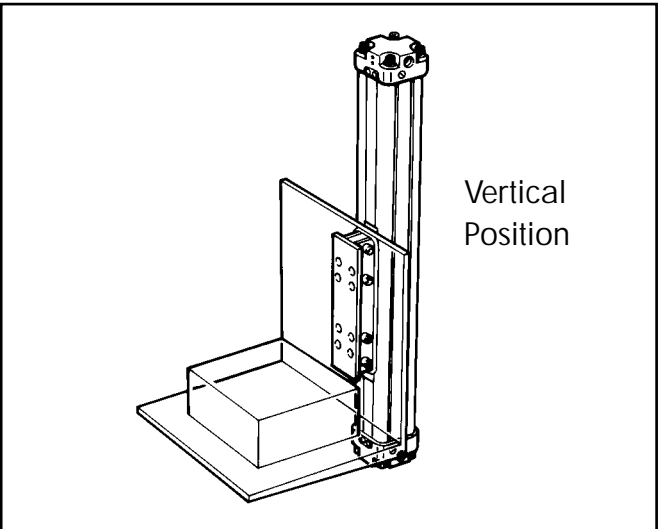
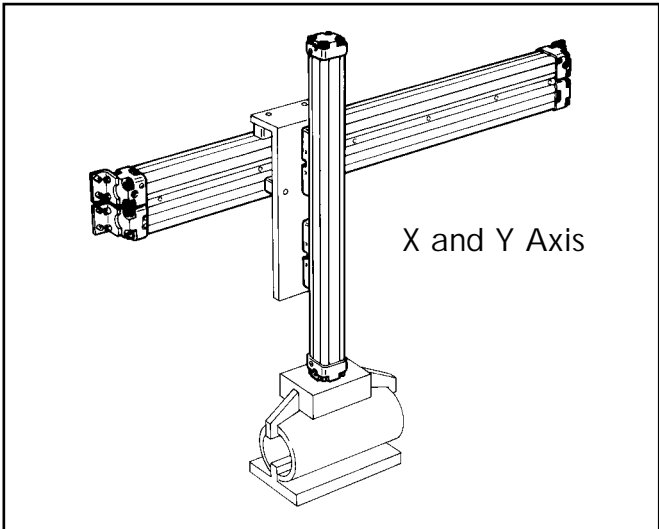
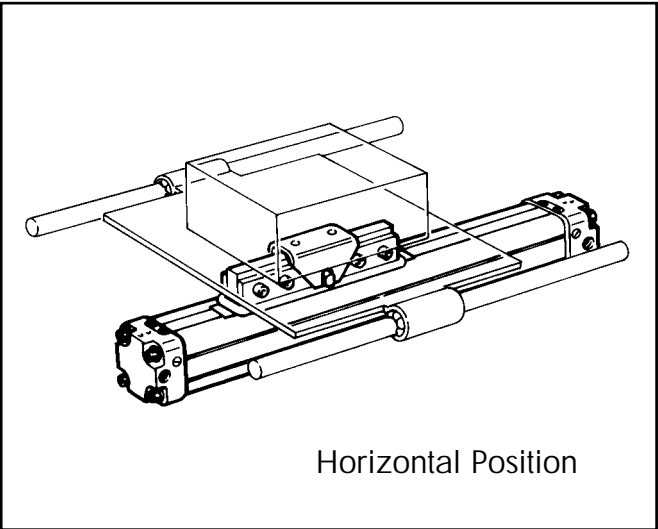
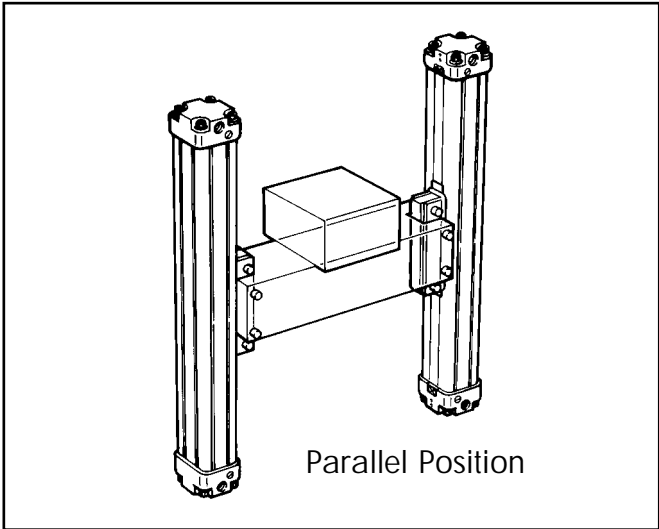

Valving

The unique, mechanical design of the Origa rodless cylinder allows for a variety of valves and pneumatic circuit configurations. The diagrams shown below illustrate circuit examples used to obtain a particular output function.

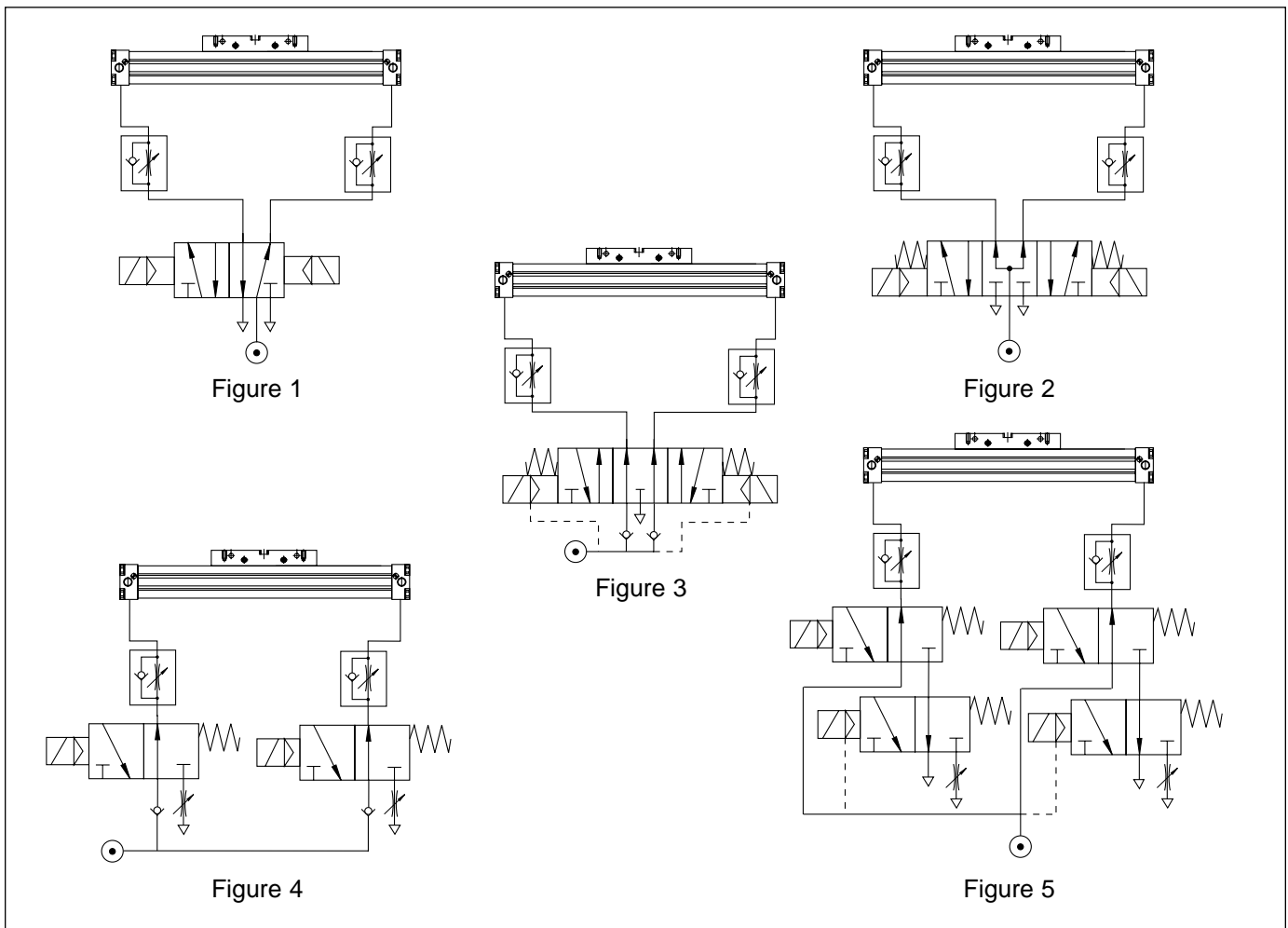

Figure 1. Speed controlled forward and backward motion.

Figure 2. For positioning when no external forces are present.

Figure 3. For accurate positioning. Check valves prevent external forces from moving the piston. Recommended for short stroke cylinders.

Figure 4. For accurate positioning. The valves should be located directly at the connection ports of the cylinder. Recommended for long stroke cylinders.

Figure 5. Recommended for accurate positioning at high velocities. Also when the load is too large to be handled by the standard cushions. An additional 3/2 way valve, including throttle control, connected to the exhaust port of the ordinary valve is used. This makes it possible to increase the throttling of the airflow before reaching positioning points or end positions. This allows a higher positioning repeatability and improved cushioning.

Applications

For more than 20 years
Origa cylinders have provided solutions
to linear motion problems
in all types of industry.

Offering simple designs,
easy installation, clean operation
and maintenance free duty,
Origa cylinders are suitable for
a diversity of applications and
environments. A variety of examples
are shown on the following pages.

For more information or
assistance with your linear
motion tasks. Please call an
authorized distributor or
Origa direct.

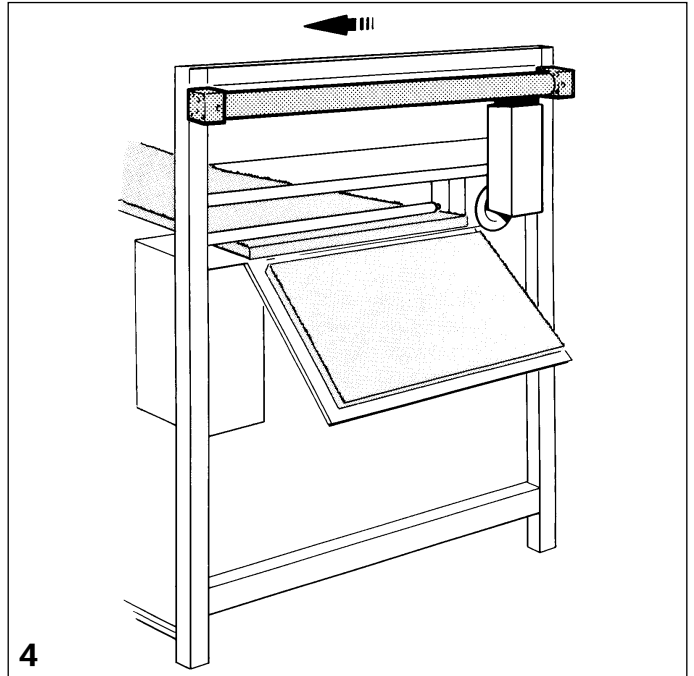
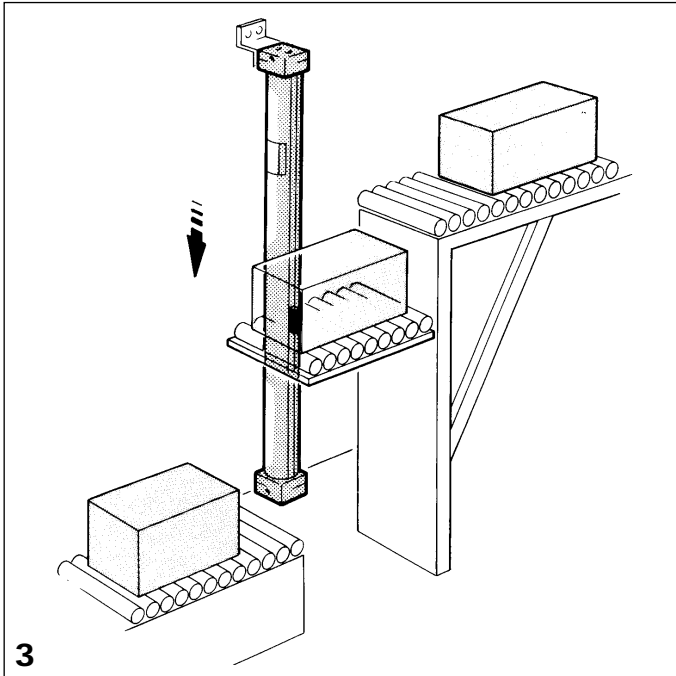
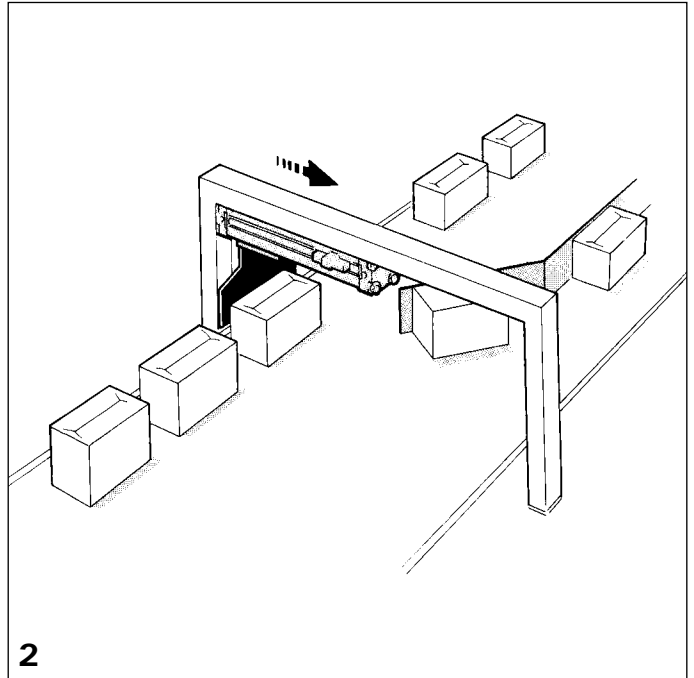
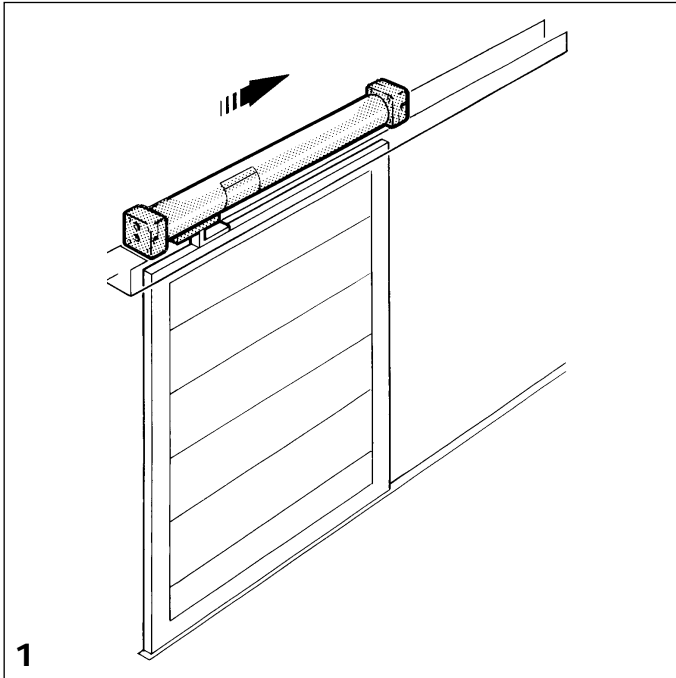

Application Descriptions

- No.1 Door Traverse -
- No.2 Conveyor Reject Systems -
- No.3 Conveyor Elevator -
- No.4 Flying Cutter -

Benefits

- Long strokes, equal forces in both directions, smooth consistent movement, space savings and ease of installation.
- Self-guiding, high-speed operation and compact design.
- Cantilever loading, self-guiding, long strokes, space saving and forms a part of the structure.
- High speeds, self-guiding, space saving, forms main structure of assembly. Made to any stroke length.

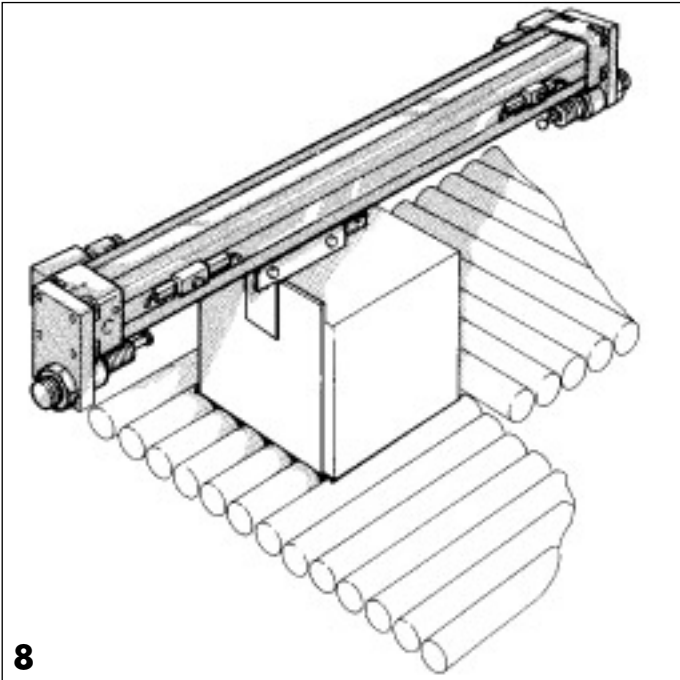
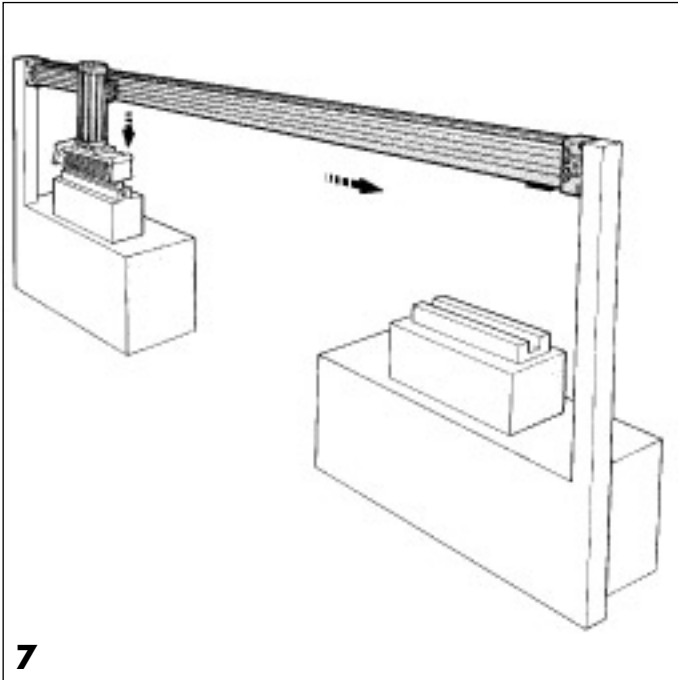
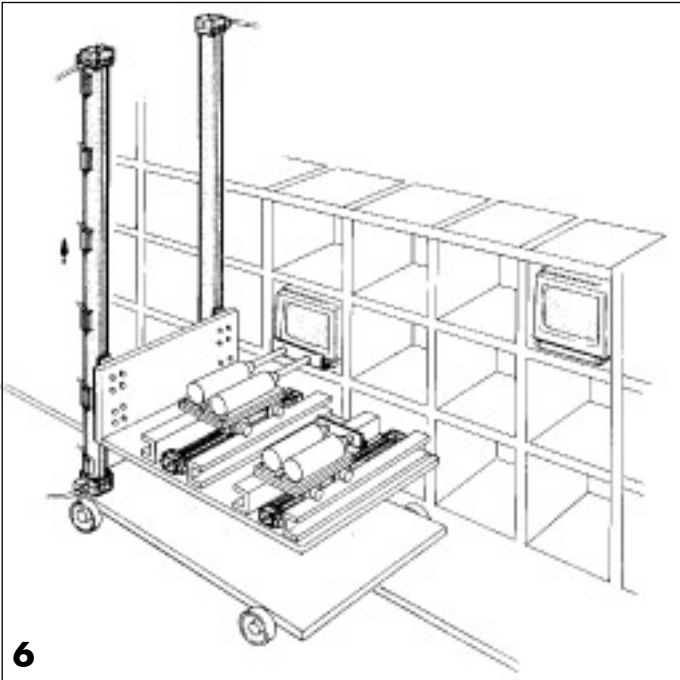
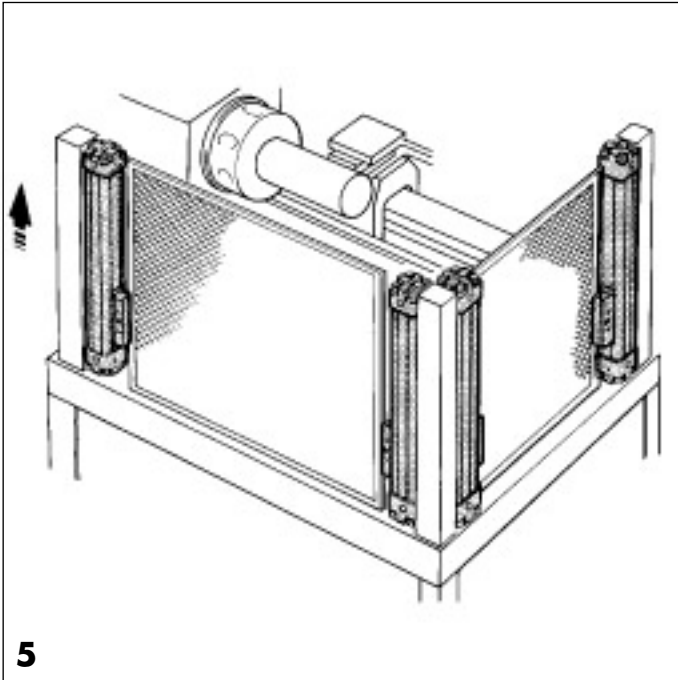

Application Descriptions

- No.5 Machine Guards -**
- No.6 Auto-Handling Systems -**
- No.7 X-Y Axis, Pick and Place -**
- No.8 Conveyor Transfer -**

Benefits

- Parallel operation, self-guiding, compact design.
- Parallel operation, self-guiding, cantilever loading, space savings and controllability.
- Self-guiding, compact design, no additional structural supports.
- Self-guiding, compact design, equal force in both directions, no additional support or guidance.

9

10

11

12

Application Descriptions

- No.9 Process Dipping -
- No.10 Belt Tracking -
- No.11 Steel Mill - Roll Wiper -
- No.12 Autohandling Systems -

Benefits

- Cantilever loading, internally guided, high load capability, slow speed controlability, design simplicity.
- Self-guiding, intermediate positioning capability, maintenance-free operation.
- Self-guiding, suitable for high-cycle duty, reliable in arduous environments.
- Multi-axis capability, intermediate positioning, no auxiliary guides or structural support, simple design.

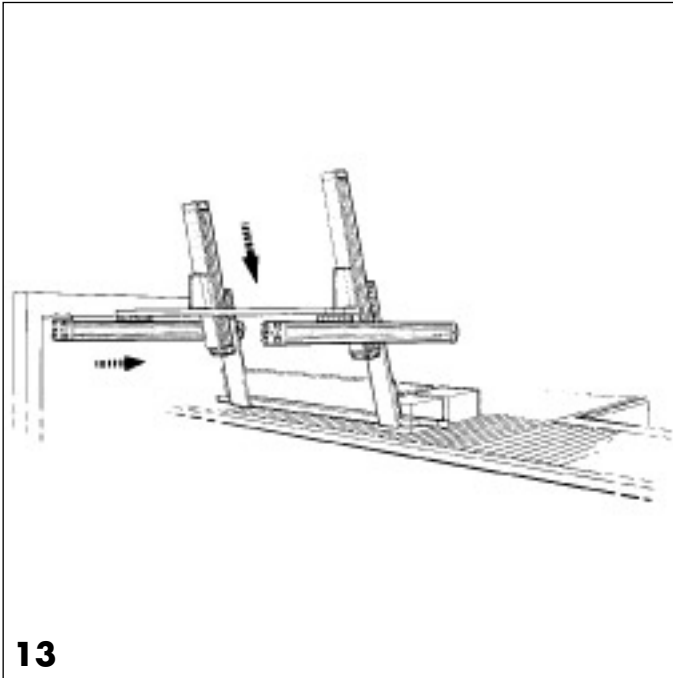

13

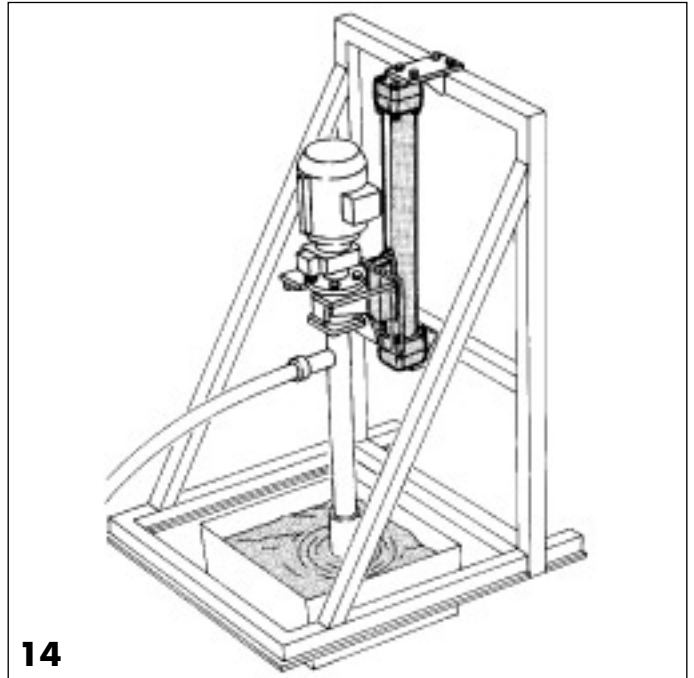

14

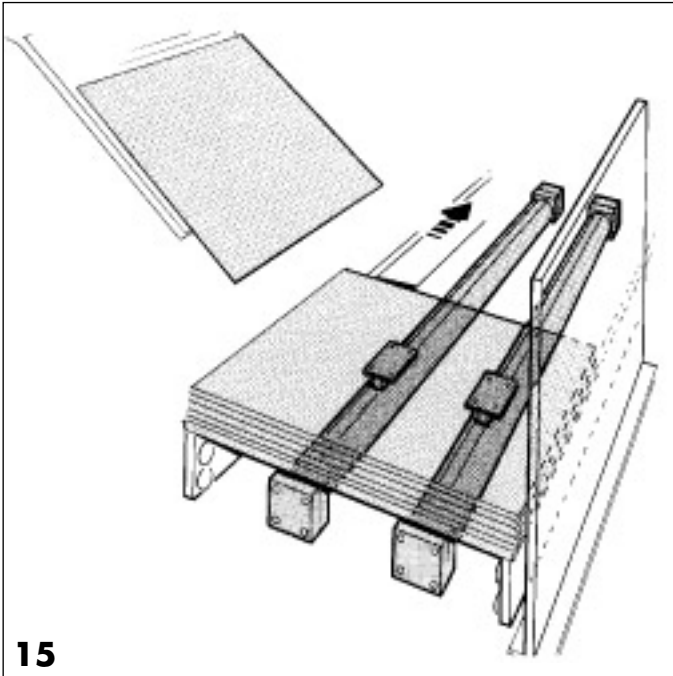

15

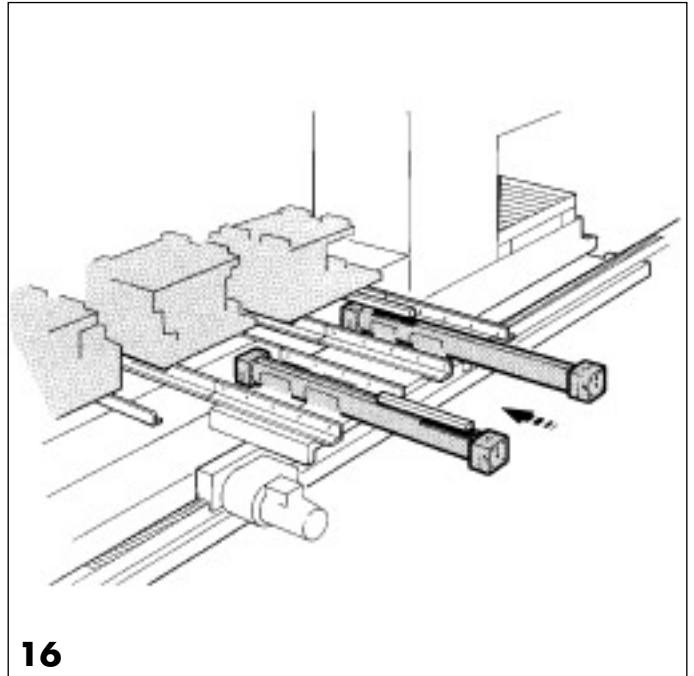

16

Application Descriptions

- No.9 Palletizing -**
- No.10 Pump Elevator -**
- No.11 Pallet Handling -**
- No.12 Tool Die Handling -**

Benefits

- Parallel operation, self-guiding, accepts high cantilever loads, inherently rigid construction.
- Accepts high cantilever loads, simple construction, minimal engineering.
- Parallel operation, controlled motion of high loads, reliability in arduous environments.
- Controlled movement of heavy loads, equal force in both directions, simple and space saving design.

Six Unique Advantages

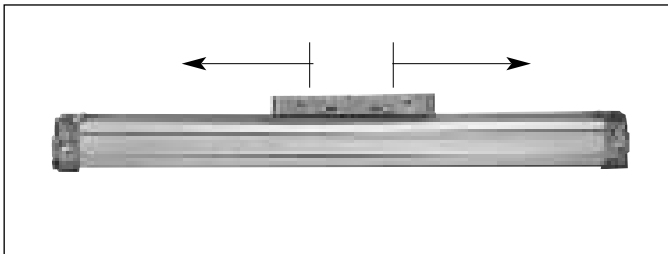

Equal Force and Speed

Equal piston area on each side of the piston allows for equal force and speed in both directions of travel. Additionally, the ability to “pneumatically lock” the piston at various points along the stroke is possible through the use of special valve configurations. (See page 2.0/2)

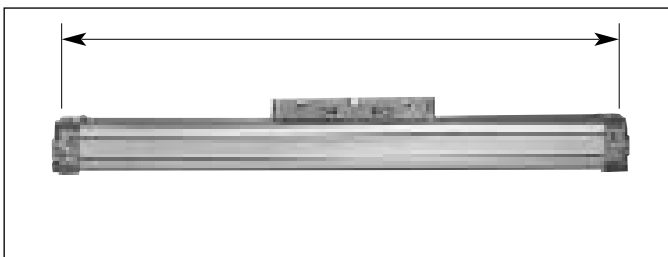

Any Length of Stroke

Infinitely variable strokes are available up to 480 inches and each cylinder is custom manufactured to customer requirements without incurring extended delivery times.

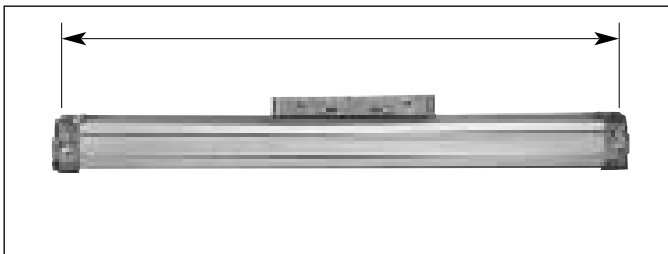

Space Saving

The lack of a piston rod allows for nearly half the space requirement of a “rod type” pneumatic cylinder. The result is a simpler, less costly installation reducing the amount of hardware and design time.

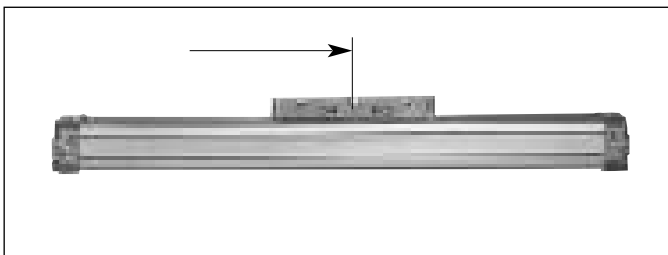

Accepts Cantilever Loads

The unique piston design and barrel rigidity allows the Origa cylinder to accept high direct and bending moment loads without the need for additional support hardware.

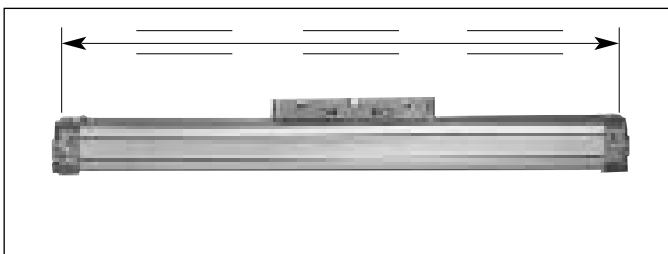

Self Guiding

The internal self-supporting characteristics of the Origa rodless cylinder provides guidance of the piston throughout the stroke. High priced guidance mechanisms (roundway bearings, precision slideways, etc.) are not required.

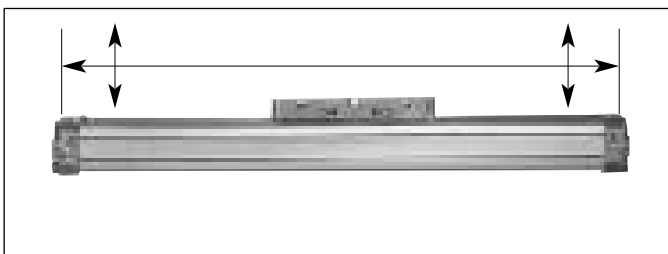

Inherent Rigidity

Integral strength and rigidity of the complete cylinder assembly will accommodate the heaviest of loads enabling the cylinder to form part of a structure or framework. This eliminates the need for expensive and bulky I-beams, channels and fabrications.