

**PNEUMATIC
GROUP**

Guides
ORIGA SYSTEM PLUS

**LINEAR GUIDES
FOR OSP-P**

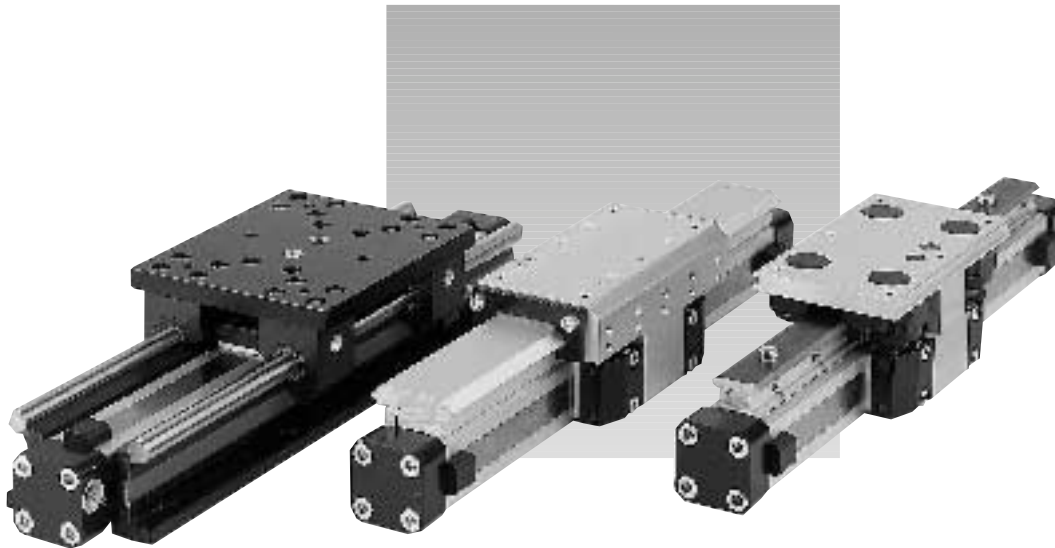

HOERBIGER
ORIGA

OSP

— ORIGA
— SYSTEM
— PLUS

Adaptive modular system

The Origa system plus – OSP – provides a comprehensive range of linear guides for the pneumatic and electric linear drives.

Versions:

Pneumatic linear drive Series OSP - P

- Piston diameters:
16 - 25 - 32 - 40 - 50 - 63 mm

Advantages:

- Takes high loads and forces
- High precision
- Smooth operation
- Can be retrofitted
- Can be installed in any position

Linear Guides

Pneumatic linear drive – Series OSP - P

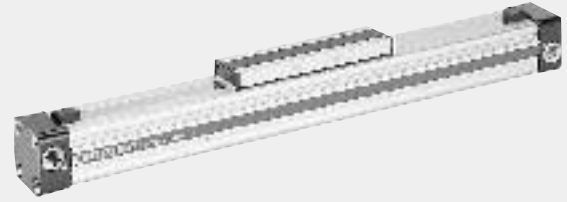

SLIDELINE

The cost-effective plain bearing guide for medium loads.
Brake optional.
See page 25

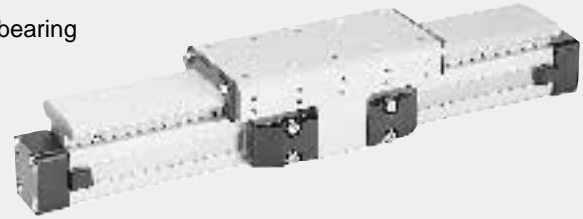

POWERSLIDE

The roller guide for heavy loads.
See page 27

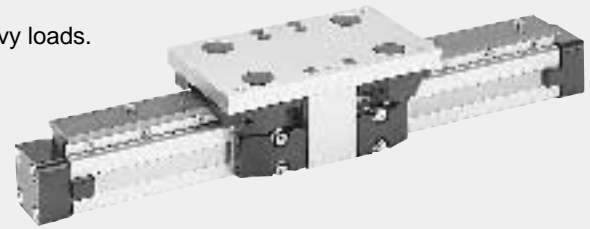

GUIDELINE

The ball bushing guide for the heaviest loads and greatest accuracy.
See page 31

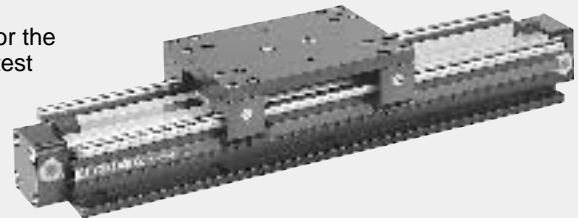

PROLINE

The compact aluminium roller guide for high loads and velocities.
See page 35

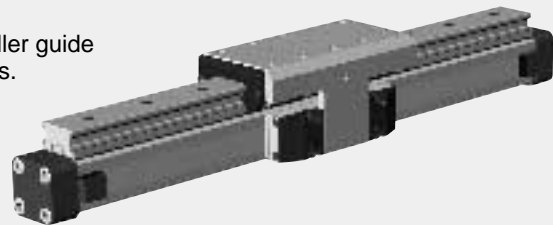

Versions

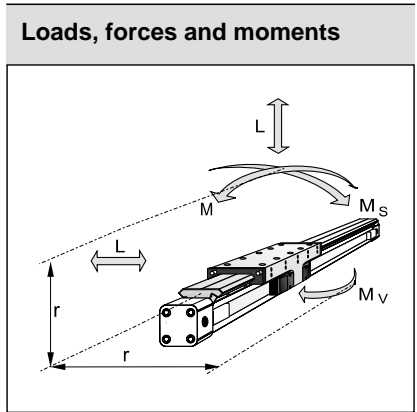
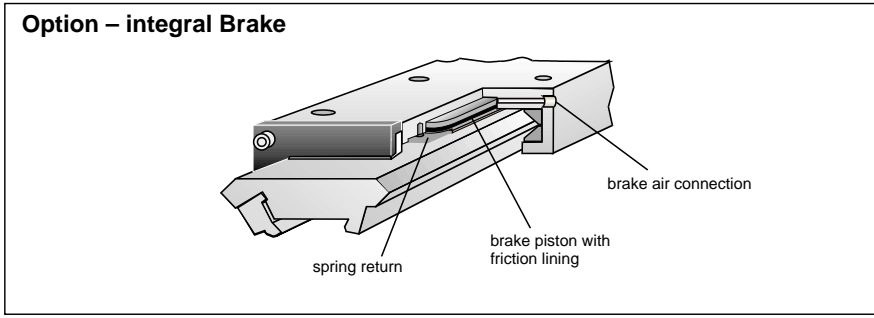
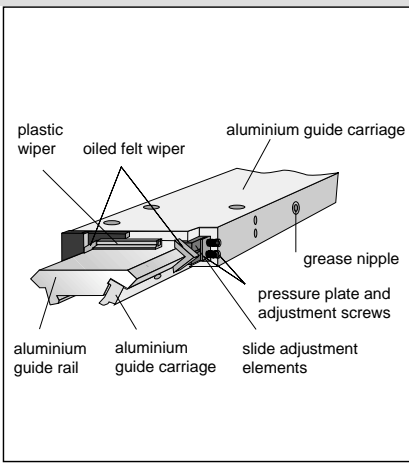

Technical Data

The table shows the maximum permissible values for smooth operation, which should not be exceeded even under dynamic conditions.

The load and moment figures apply to speeds $v < 0.2$ m/s.

*** Please note:**
 In the cushioning diagram, add the mass of the guide carriage to the mass to be cushioned.

Series	For linear drive	Max. moments [Nm]			Max. loads [N]	Maximum braking force at 6 bar [N] ¹⁾	Mass of linear drive with guide [kg]		Mass* of guide carriage [kg]
		M	Ms	Mv			with 0 mm stroke OSP-P	increase per 100 mm stroke OSP-P	
SL16	OSP-P16	11	6	11	325	–	0.57	0.22	0.23
SL25	OSP-P25	34	14	34	675	325	1.55	0.39	0.61
SL32	OSP-P32	60	29	60	925	545	2.98	0.65	0.95
SL40	OSP-P40	110	50	110	1500	835	4.05	0.78	1.22
SL50	OSP-P50	180	77	180	2000	1200	6.72	0.97	2.06
SL63	OSP-P63	260	120	260	2500	–	11.66	1.47	3.32

¹⁾ Only with integrated brake: Braking force on dry oil-free surface
 Values are decreased for lubricated slideways

²⁾ Corrosion resistant fixtures available on request

Plain Bearing Guide SLIDELINE



Series SL 16 to 63
for Linear-drive
 • **Series OSP-P**

- Features:**
- ANODIZED aluminium guide rail with prism-shaped slideway arrangement
 - Adjustable plastic slide elements – optional with integral brake
 - Composite sealing system with plastic and felt wiper elements to remove dirt and lubricate the slideways.
 - Corrosion resistant version available on request.
 - Speeds over 300mm per second, consult factory.

- Integral brake (option)**
for series OSP-P25 to OSP-P63:
- Actuated by pressure
 - Released by exhausting and spring return

For further technical data see also linear drives OSP-P (page 13)

The right to introduce technical modifications is reserved



Dimensions

Series OSP-P

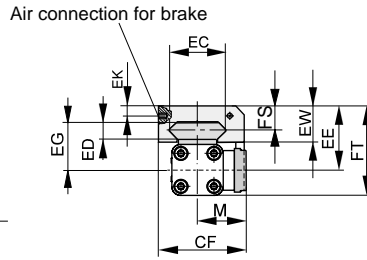
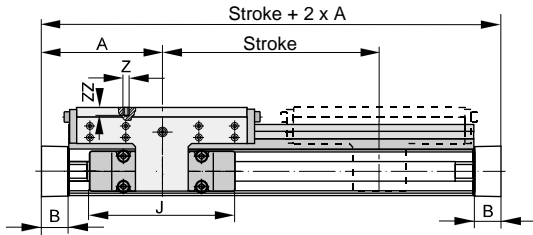

For further mounting elements and options see accessories.

For further information and technical data see data sheets for linear drives OSP-P (page 13)

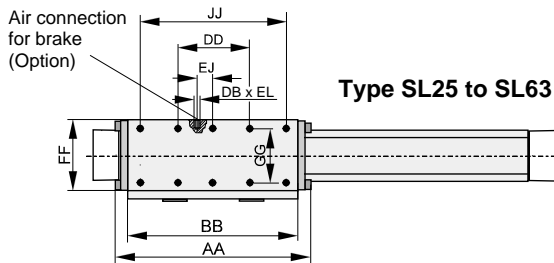

Type SL25 to SL63

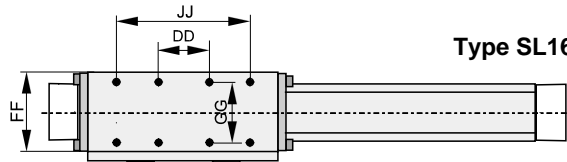

Type SL16

Dimension Table (mm)

Series	A	B	J	M	Z	AA	BB	DB	DD	CF	EC	ED	EE	EG	EJ	EK	EL	EW	FF	FT	FS	GG	JJ	ZZ
SL16	65	14	69	30	M4	106	88	M5	30	55	36	8	40	30	-	-	-	22	48	55	14	36	70	8
SL25	100	22	117	39.5	M6	162	142	G1/8	60	72.5	47	12	53	39	22	6	6	30	64	73.5	20	50	120	12
SL32	125	25.5	152	48	M6	205	185	G1/8	80	91	67	14	62	48	32	6	6	33	84	88	21	64	160	12
SL40	150	28	152	54	M6	240	220	G1/8	100	102	77	14	64	50	58	6	6	34	94	98.5	21.5	78	200	12
SL50	175	33	200	61	M6	284	264	G1/8	120	117	94	14	75	56	81	6	6	39	110	118.5	26	90	240	16
SL63	215	38	256	79	M8	312	292	G1/8	130	152	116	18	86	66	-	-	-	46	152	139	29	120	260	14

Mid-Section Support

(for versions see page 56)

Mid-section supports are required from a certain stroke length to prevent excessive deflection and vibration of the linear drive. The diagrams show the maximum permissible unsupported length in relation to loading.

A distinction must be drawn between loading 1 and loading 2. Deflection of 0.5 mm max. between supports is permissible.

Note:

For speeds $v > 0.5$ m/s the distance between supports should not exceed 1m.

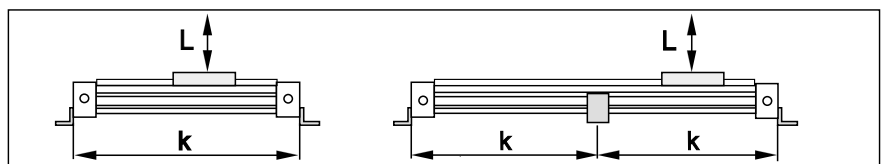
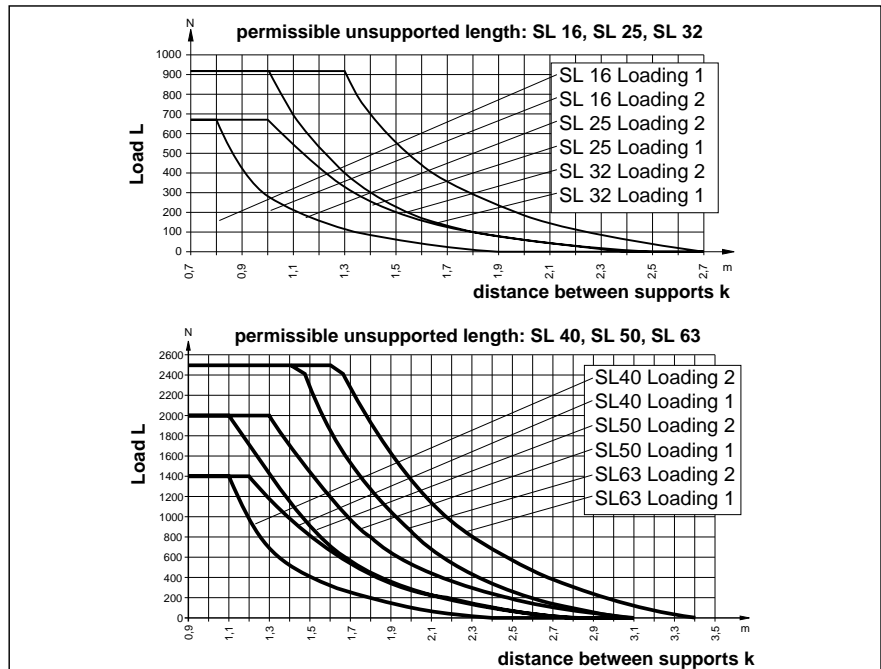
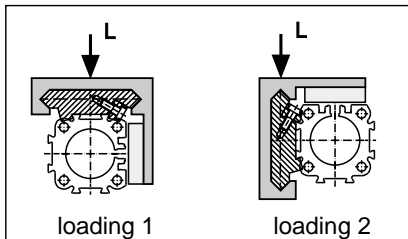

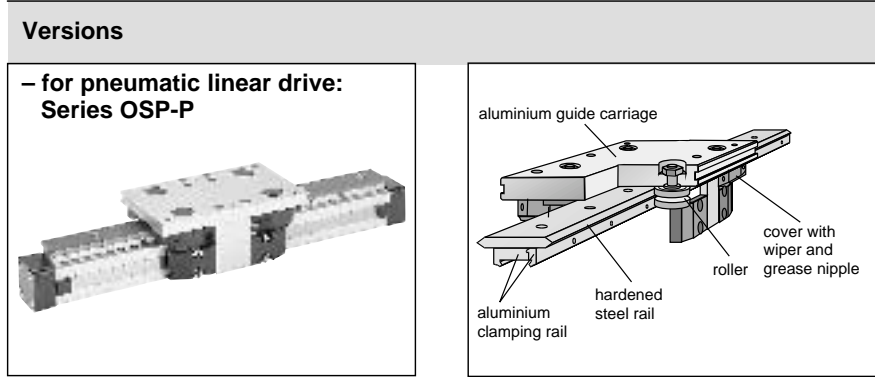

Roller Guide POWERSLIDE



**Series PS 16 to 50
for Linear-drive
• Series OSP-P**

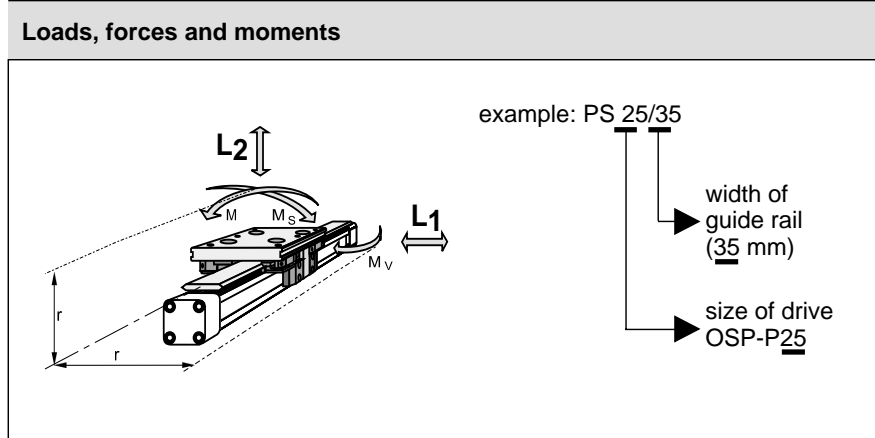

- Features:**
- Anodized aluminium guide carriage with vee rollers having 2 rows of ball bearings
 - Hardened steel guide rail
 - Several guide sizes can be used on the same drive
 - Corrosion resistance version available on request
 - Max. speed $v = 3 \text{ m/s}$,
 - Tough roller cover with wiper and grease nipple
 - Any length of stroke up to 3500 mm, (longer strokes on request)

Technical Data

The Table shows the maximum permissible values for smooth operation, which should not be exceeded even under dynamic conditions.

For further information and technical data see data sheets for linear drives OSP-P (page 13)

*** Please note:**
In the cushioning diagram, add the mass of the guide carriage to the mass to be cushioned.

Series	For linear drive	Max. moments [Nm]			Max. load [N]	Mass of linear drive with guide [kg]		Mass* of guide carriage [kg]
		M	Ms	Mv		with 0 mm stroke	increase per 100 mm stroke	
PS 16/25	OSP-P16	45	14	45	1400	0.93	0.24	0.7
PS 25/25	OSP-P25	63	14	63	1400	1.5	0.4	0.7
PS 25/35	OSP-P25	70	20	70	1400	1.7	0.4	0.8
PS 25/44	OSP-P25	175	65	175	3000	2.6	0.5	1.5
PS 32/35	OSP-P32	70	20	70	1400	2.6	0.6	0.8
PS 32/44	OSP-P32	175	65	175	3000	3.4	0.7	1.5
PS 40/44	OSP-P40	175	65	175	3000	4.6	1.1	1.5
PS 40/60	OSP-P40	250	90	250	3000	6	1.3	2.2
PS 50/60	OSP-P50	250	90	250	3000	7.6	1.4	2.3
PS 50/76	OSP-P50	350	140	350	4000	11.5	1.8	4.9

¹⁾ corrosion resistance version available on request (max. loads and moments are 25% lower)

The right to introduce technical modifications is reserved



Dimensions

Series OSP-P

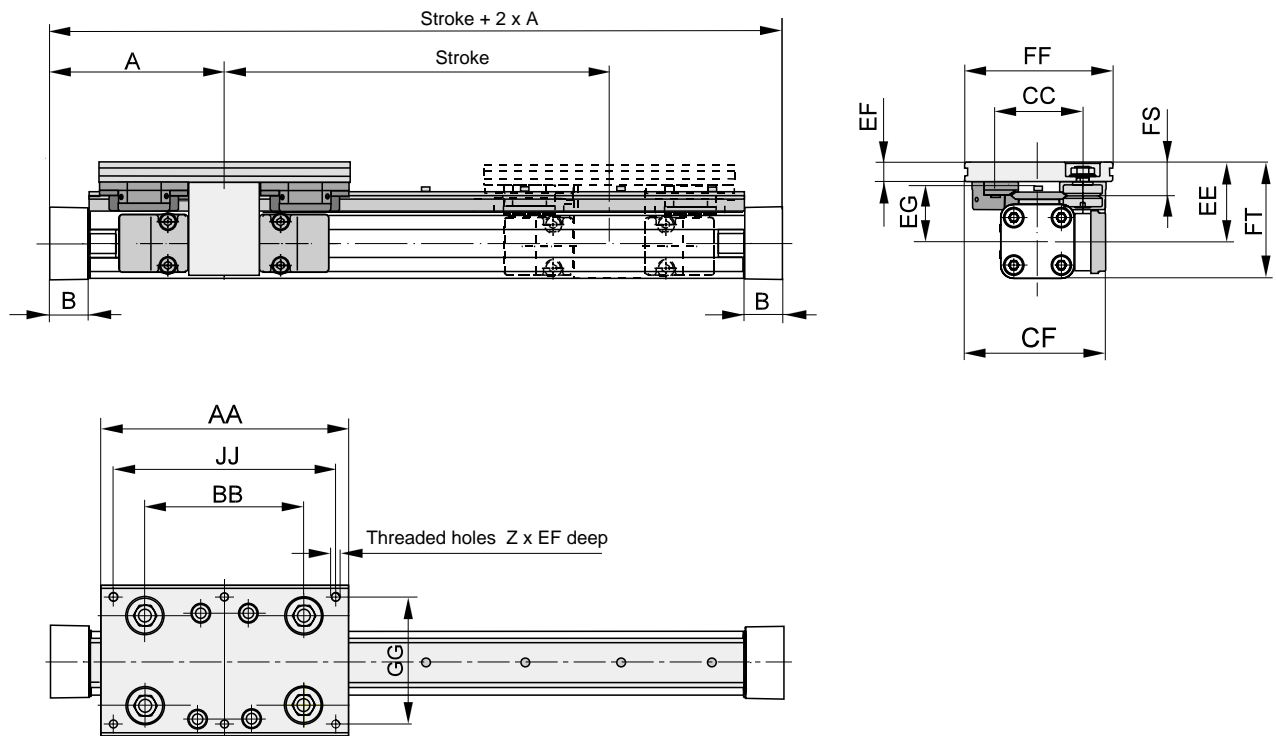

Dimension Table (mm)

Series	A	B	Z	AA	BB	CC	CF	EE	EF	EG	FF	FS	FT	GG	JJ
PS16/25	65	14	4xM6	120	65	47	80	49	12	35	80	21	64	64	100
PS25/25	100	22	6xM6	145	90	47	79.5	53	11	39	80	20	73.5	64	125
PS25/35	100	22	6xM6	156	100	57	89.5	52.5	12.5	37.5	95	21.5	73	80	140
PS25/44	100	22	6xM8	190	118	73	100	58	15	39	116	26	78.5	96	164
PS32/35	125	25.5	6xM6	156	100	57	95.5	58.5	12.5	43.5	95	21.5	84.5	80	140
PS32/44	125	25.5	6xM8	190	118	73	107	64	15	45	116	26	90	96	164
PS40/44	150	28	6xM8	190	118	73	112.5	75	15	56	116	26	109.5	96	164
PS40/60	150	28	6xM8	240	167	89	122.5	74	17	54	135	28.5	108.5	115	216
PS50/60	175	33	6xM8	240	167	89	130.5	81	17	61	135	28.5	123.5	115	216
PS50/76	175	33	6xM10	280	178	119	155.5	93	20	64	185	39	135.5	160	250

Mid-Section Support

(for versions, see page 56)

Mid section supports are required from a certain stroke length to prevent excessive deflection and vibration of the linear drive. The diagrams show the maximum permissible unsupported length in relation to loading.

A distinction must be drawn between loading 1 and loading 2.

Deflection of 0.5 mm max. between supports is permissible.

Note

For speeds $v > 0.5$ m/s the distance between supports should not exceed 1m.

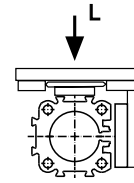
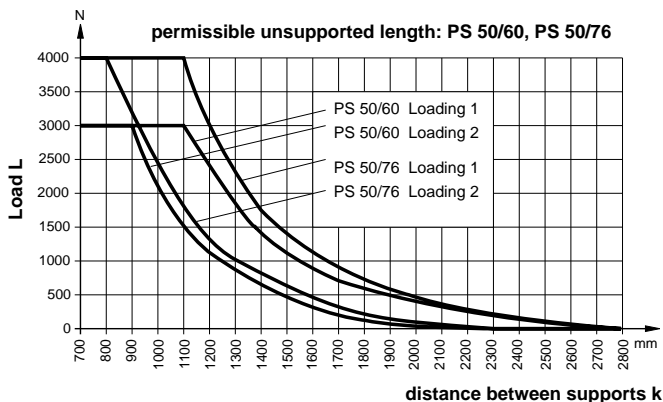
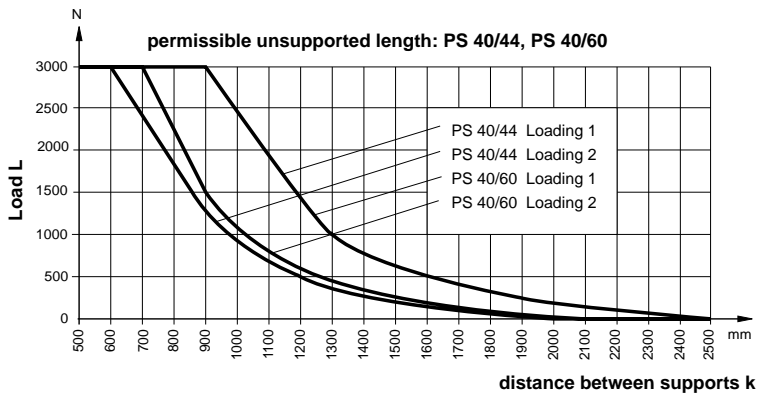
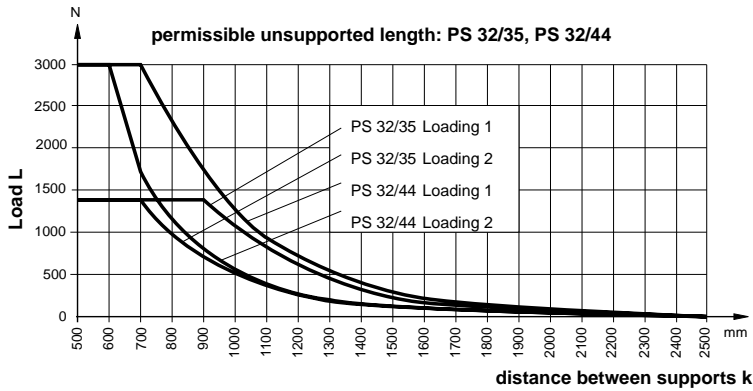
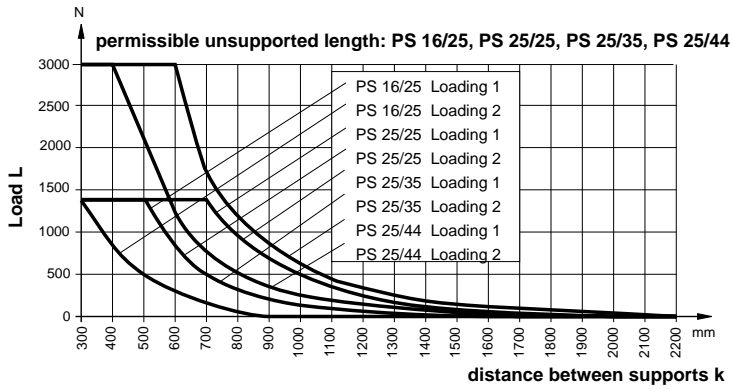

loading 1

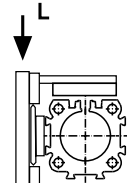

loading 2

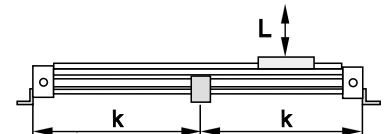
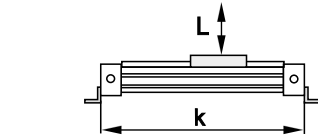

Service life

Calculation of service life is achieved in two stages:

- Determination of load factor L_F from the loads to be carried
- Calculation of service life in km

Lubrication

For maximum system life, lubrication of the rollers must be maintained at all times.

Only high quality Lithium based greases should be used.

Lubrication intervals are dependant on environmental conditions (temperature, running speed, grease quality etc.) therefore the installation should be regularly inspected.

1. Calculation of load factor L_F

$$L_F = \frac{M}{M_{\max}} + \frac{M_S}{M_{S \max}} + \frac{M_V}{M_{V \max}} + \frac{L_1}{L_{1 \max}} + \frac{L_2}{L_{2 \max}}$$

with combined loads, L_F should not exceed the value 1.

2. Calculation of service life

• For PS 16/25, PS 25/25, PS 25/35, and PS 32/35	Service life [km] = $\frac{106}{(L_F + 0.02)^3}$
• For PS 25/44, PS 32/44, PS 40/44, PS 40/60 and PS 50/60:	Service life [km] = $\frac{314}{(L_F + 0.015)^3}$
• For PS 50/76:	Service life [km] = $\frac{680}{(L_F + 0.015)^3}$

Versions

– Versions for linear drive Series OSP-P

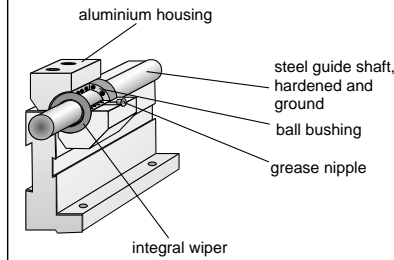
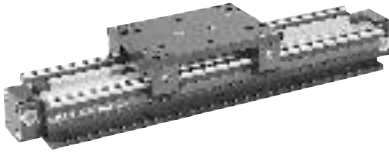

Ball bushing guide GUIDELINE

OSP
— ORIGA
— SYSTEM
— PLUS

**Series GDL 25 to 50
for Linear-drive
• Series OSP-P**

Loads, forces and moments

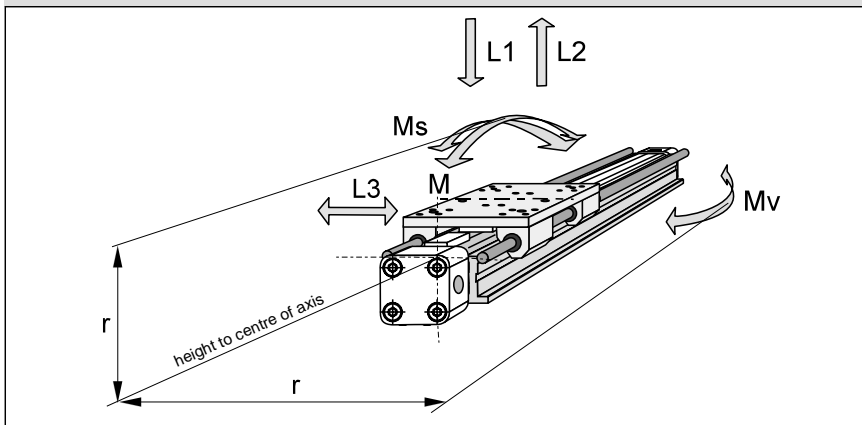

Technical Data

The Table shows the maximum permissible values for smooth operation, which should not be exceeded even under dynamic conditions.

For further information and technical data see data sheets for linear drives OSP-P (page 13)

* Please note:

In the cushioning diagram, add the mass of the guide carriage to the mass to be cushioned.

Features

- Anodized aluminium guide rail with four ball bushings
- Hardened and ground steel guide shafts
- Stainless steel guide shafts available on request
- Max. speed $v = 3$ m/s
- OSP-P: smooth slow speed operation $v_{\min} \geq 0.02$ m/s.
- Any length of stroke up to 6000 mm (longer strokes on request)

Series	For linear drive	Max. moments [Nm]			Max. load [N]			Mass of linear drive with guide [kg]		Mass* of guide carriage [kg]
		M	Ms	Mv	L ₁	L ₂	L ₃	with 0 mm stroke	increase p. 100 mm stroke	
GDL 25	OSP-P25	115	75	90	2500	2100	1650	2.5	0.7	1.1
GDL 32	OSP-P32	145	90	115	2500	2100	1650	3.6	0.9	1.2
GDL 40	OSP-P40	440	330	310	8000	6250	4400	6.3	1.4	2.0
GDL 50	OSP-P50	500	375	355	8000	6250	4400	8.6	1.6	2.2

¹⁾ corrosion resistance version available on request (max. loads and moments are 30% lower)

Dimensions

Series OSP-P

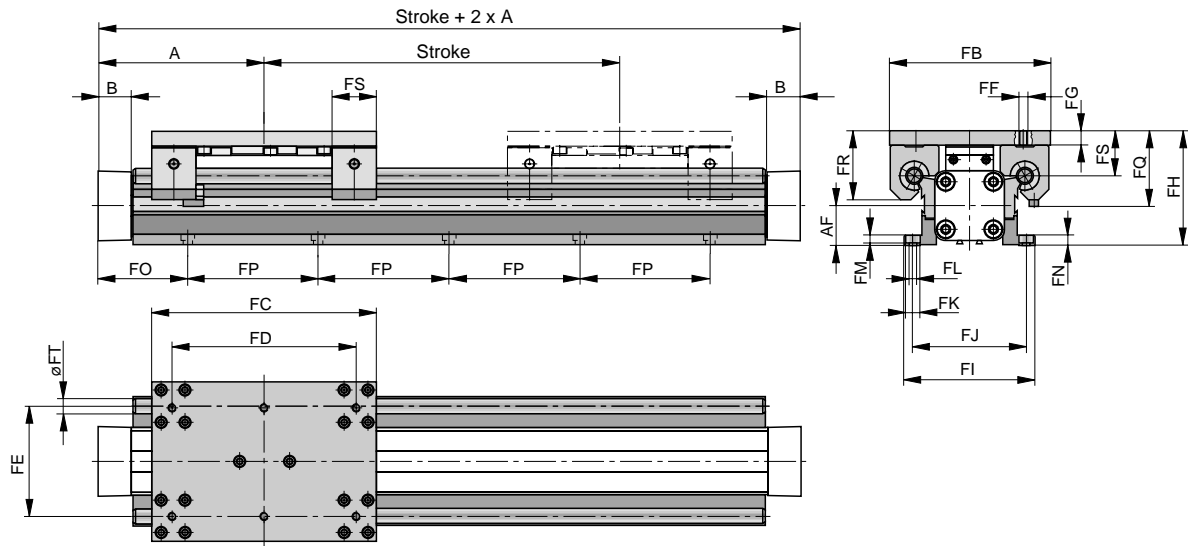

Note:

The guideline linear guide must be mounted on a flat surface along its entire length.

Arrangement of proximity sensors:

Proximity sensors can be fitted anywhere on either side. The magnet can be screwed on to one of the four ball bushing housings from underneath.

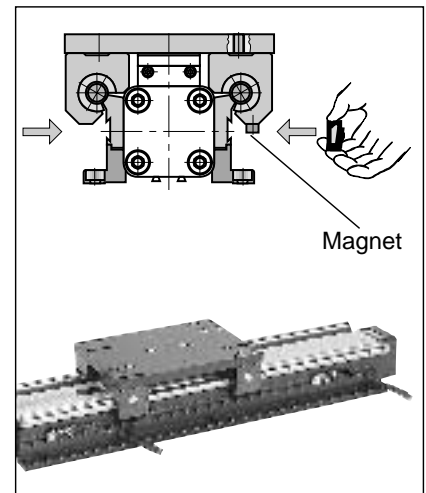

Dimension Table (mm)

Series	A	B	AF	FB	FC	FD	FE	FF	FG	FH	FI	FJ	øFK	øFL	FM	FN	FP	FQ	FR	FS	øFT	FU
GDL 25	100	22	22	120	145	110	70	M6	11	78	86	73	10.5	6.0	5.7	8	100	56.5	51.5	33.5	12	32
GDL 32	125	25.5	30	120	170	140	80	M6	11	86	98	85	10.5	6.0	5.7	8	100	56.5	51.5	33.5	12	32
GDL 40	150	28	38	160	180	140	110	M8	14	108	120	104	12	7.5	6.8	10	100	73	61	38	16	36
GDL 50	175	33	48	180	200	160	120	M8	14	118	134	118	12	7.5	6.8	10	100	73	61	38	16	36

FO				
OSP-P				
x	P25	P32	P40	P50
00	50.0	75.0	50.0	75.0
01	50.5	75.5	50.5	75.5
02	51.0	76.0	51.0	76.0
03	51.5	76.5	51.5	76.5
04	52.0	77.0	52.0	77.0
05	52.5	77.5	52.5	77.5
06	53.0	78.0	53.0	78.0
07	53.5	78.5	53.5	78.5
08	54.0	79.0	54.0	79.0
09	54.5	79.5	54.5	79.5
10	55.0	80.0	55.0	80.0
11	55.5	80.5	55.5	80.5
12	56.0	81.0	56.0	81.0
13	56.5	81.5	56.5	81.5
14	57.0	82.0	57.0	82.0
15	57.5	82.5	57.5	82.5
16	58.0	83.0	58.0	83.0
17	58.5	83.5	58.5	83.5
18	59.0	84.0	59.0	84.0
19	59.5	84.5	59.5	84.5
20	60.0	85.0	60.0	85.0
21	60.5	85.5	60.5	85.5
22	61.0	86.0	61.0	86.0
23	61.5	86.5	61.5	86.5
24	62.0	87.0	62.0	87.0
25	62.5	87.5	62.5	87.5
26	63.0	88.0	63.0	88.0
27	63.5	88.5	63.5	88.5
28	64.0	89.0	64.0	89.0
29	64.5	89.5	64.5	89.5
30	65.0	90.0	65.0	90.0
31	65.5	90.5	65.5	90.5
32	66.0	91.0	66.0	91.0
33	66.5	91.5	66.5	91.5
34	67.0	92.0	67.0	92.0
35	67.5	92.5	67.5	92.5
36	68.0	93.0	68.0	93.0
37	68.5	93.5	68.5	93.5
38	69.0	94.0	69.0	94.0
39	69.5	94.5	69.5	94.5
40	70.0	95.0	70.0	95.0
41	70.5	95.5	70.5	95.5
42	71.0	96.0	71.0	96.0
43	71.5	96.5	71.5	96.5
44	72.0	97.0	72.0	97.0
45	72.5	97.5	72.5	97.5
46	73.0	98.0	73.0	98.0
47	73.5	98.5	73.5	98.5
48	74.0	99.0	74.0	99.0
49	74.5	99.5	74.5	99.5

FO				
OSP-P				
x	P25	P32	P40	P50
50	75.0	50.0	75.0	50.0
51	75.5	50.5	75.5	50.5
52	76.0	51.0	76.0	51.0
53	76.5	51.5	76.5	51.5
54	77.0	52.0	77.0	52.0
55	77.5	52.5	77.5	52.5
56	78.0	53.0	78.0	53.0
57	78.5	53.5	78.5	53.5
58	79.0	54.0	79.0	54.0
59	79.5	54.5	79.5	54.5
60	80.0	55.0	80.0	55.0
61	80.5	55.5	80.5	55.5
62	81.0	56.0	81.0	56.0
63	81.5	56.5	81.5	56.5
64	82.0	57.0	82.0	57.0
65	82.5	57.5	82.5	57.5
66	83.0	58.0	83.0	58.0
67	83.5	58.5	83.5	58.5
68	84.0	59.0	84.0	59.0
69	84.5	59.5	84.5	59.5
70	85.0	60.0	85.0	60.0
71	85.5	60.5	85.5	60.5
72	86.0	61.0	86.0	61.0
73	86.5	61.5	86.5	61.5
74	87.0	62.0	87.0	62.0
75	87.5	62.5	87.5	62.5
76	88.0	63.0	88.0	63.0
77	88.5	63.5	88.5	63.5
78	89.0	64.0	89.0	64.0
79	89.5	64.5	89.5	64.5
80	90.0	65.0	90.0	65.0
81	90.5	65.5	90.5	65.5
82	91.0	66.0	91.0	66.0
83	91.5	66.5	91.5	66.5
84	92.0	67.0	92.0	67.0
85	92.5	67.5	92.5	67.5
86	93.0	68.0	93.0	68.0
87	93.5	68.5	93.5	68.5
88	94.0	69.0	94.0	69.0
89	94.5	69.5	94.5	69.5
90	95.0	70.0	95.0	70.0
91	95.5	70.5	95.5	70.5
92	96.0	71.0	96.0	71.0
93	96.5	71.5	96.5	71.5
94	97.0	72.0	97.0	72.0
95	97.5	72.5	97.5	72.5
96	98.0	73.0	98.0	73.0
97	98.5	73.5	98.5	73.5
98	99.0	74.0	99.0	74.0
99	99.5	74.5	99.5	74.5

Note:

The dimension FO is derived from the last two digits of the stroke:

Example:

Stroke 15 **25** mm



For a cylinder OSP-P25 the adjacent table indicates that for x=25mm:

FO = 62.5 mm

System Life

The calculation for expected service life is achieved in three steps:

- Determination of the load factor L_F , inserting actual values into the adjacent equation
- Determination of guidance constant K_F
- Calculation of the service life in km

Lubrication

For maximum system life, lubrication of the ball bushings must be maintained at all times.

Only high quality Lithium based greases should be used.

Lubrication intervals are dependant on environmental conditions (temperature, running speed, grease quality etc.) therefore the installation should be regularly inspected.

1. Calculation of load factor L_F

$$L_F = \frac{M}{M_{\max}} + \frac{M_S}{M_{S \max}} + \frac{M_V}{M_{V \max}} + \frac{L_1}{L_{1 \max}} + \frac{L_2}{L_{2 \max}} + \frac{L_3}{L_{3 \max}}$$

with combined loads, L_F should not exceed the value 1.

2. Guidance constant K_F

Installation	guidance constant K_F	
	GDL 25, GDL 32	GDL 40, GDL 50
Horizontal	200	210
Sideways	250	320
Vertical	90	120

3. Service life calculation

Approximate service life is calculated using the following equation:

$$\text{Service life [km]} = \frac{K_F}{L_F^3}$$

Versions

Standard versions
– for pneumatic Linear Drive:
Series OSP-P

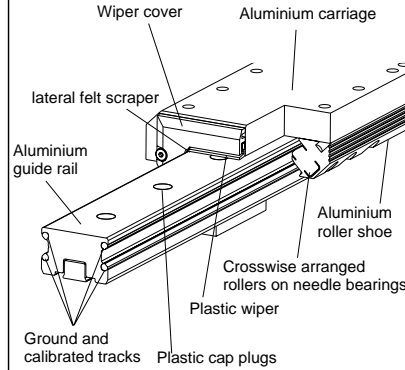
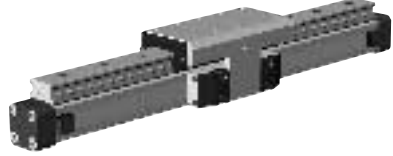

Aluminium Roller Guide PROLINE

OSP
— ORIGA
— SYSTEM
— PLUS

Series PL 25 to 50
for Linear Drive
• Series OSP-P

Option – Integrated Brake

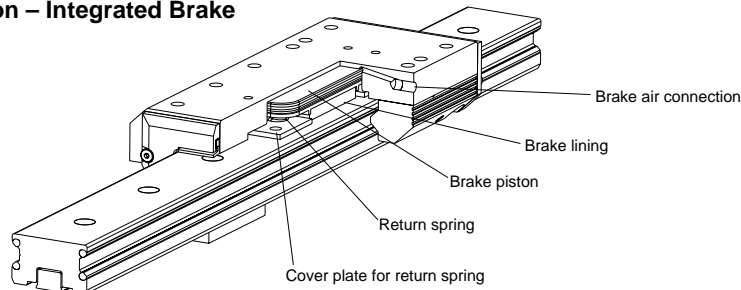

Features:

- High precision
- High velocities (10 m/s)*
- Smooth operation - low noise
- Integrated wiper system
- Long life lubrication
- Compact dimensions - compatible to Slideline plain bearing guide
- Stainless steel version available on request
- Any length of stroke up to 3750 mm

Loads, Forces and Moments

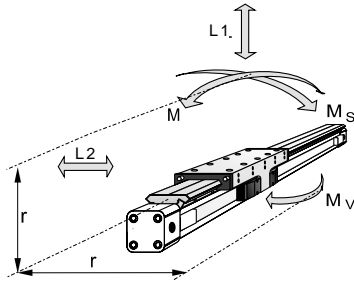

Technical Data

The table shows the maximal permissible loads. If multiple moments and forces act upon the cylinder simultaneously, the following equation applies:

$$\frac{M}{M_{\max}} + \frac{M_s}{M_{s \max}} + \frac{M_v}{M_{v \max}} + \frac{L_1}{L_{1 \max}} + \frac{L_2}{L_{2 \max}} \leq 1$$

The sum of the loads should not exceed >1

The table shows the maximum permissible values for light, shock-free operation, which must not be exceeded even under dynamic conditions.

Integrated Brake (optional) for Series OSP-P25 to OSP-P50:

- Actuated by pressurization
- Release by depressurisation and spring actuation

Please note:

The mass of the carriage has to be added to the total moving mass when using the cushioning diagram.

*Consult factory

Series	For linear drive	Max. moments [Nm]			Max. loads [N]	Maximum braking force at 6 bar [N] ¹⁾	Mass of linear drive with guide [kg]		Mass* guide carriage [kg]
		M	Ms	Mv			L1, L2	with 0 mm stroke	
PL 25	OSP-P-25	55	23	55	1210	on request	1.65	0.40	0.75
PL 32	OSP-P-32	91	36	91	1460	on request	3.24	0.62	1.18
PL 40	OSP-P-40	198	72	198	2600	on request	4.35	0.70	1.70
PL 50	OSP-P-50	313	139	313	3890	on request	7.03	0.95	2.50

¹⁾ Only for version with brake:

Braking surface dry – oiled surface reduces the effective braking force.

²⁾ Stainless steel version on request

Dimension Table (mm) Series OSP-P PL25, PL32, PL40, PL50

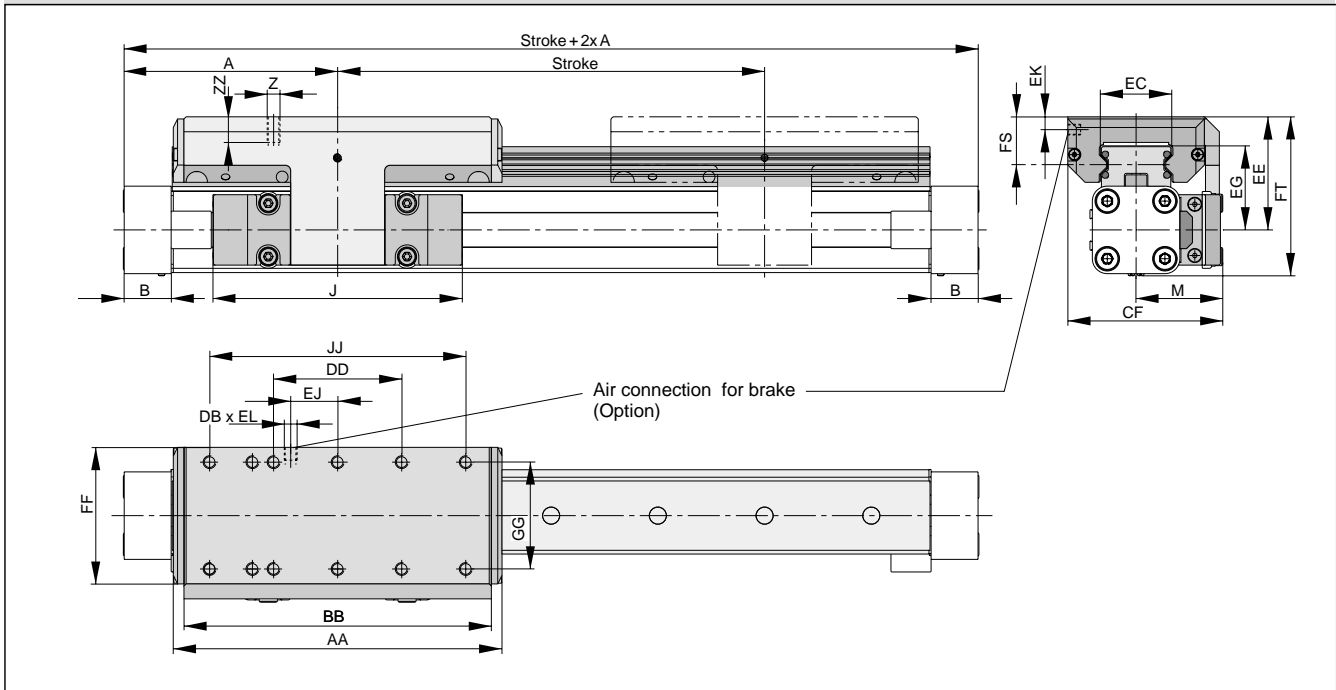

Dimension Table (mm) Series OSP-P PL25, PL32, PL40, PL50

Serie	A	B	J	M	Z	AA	BB	DB	DD	CF	EC	EE	EG	EJ	EK	EL	FF	FS	FT	GG	JJ	ZZ
PL25	100	22	117	40.5	M6	154	144	M5	60	72.5	32.5	53	39	22	6	6	64	23	73.5	50	120	12
PL32	125	25.5	152	49	M6	197	187	M5	80	91	42	62	48	32	6	6	84	25	88	64	160	12
PL40	150	28	152	55	M6	232	222	M5	100	102	47	64	50.5	58	6	6	94	23.5	98.5	78	200	12
PL50	175	33	200	62	M6	276	266	M5	120	117	63	75	57	81	6	6	110	29	118.5	90	240	16

Mid-Section Support

(For versions, see page 56)

Mid-section supports are required from a certain stroke length to prevent excessive deflection and vibration of the linear drive. The diagrams show the maximum permissible unsupported length in relation to loading. A distinction must be drawn between loading 1 and loading 2. Deflection of 0.5 mm max. between supports is permissible.

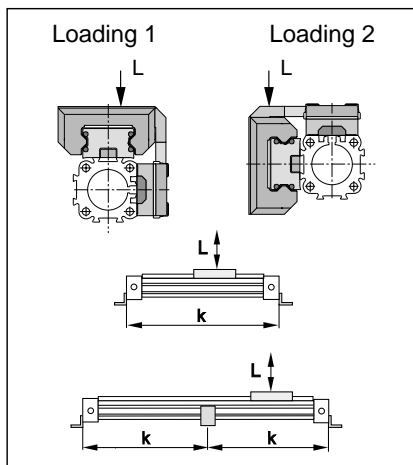

Note:

For speeds $v > 0.5$ m/s the distance between supports should not exceed 1m.

Permissible Unsupported Length PL25, PL32, PL40 and PL50

