

FSE Blocking Cylinder

Specifications

Characteristics	Symbol	Unit	Comments
General Characteristics			
Description			Blocking Unit (Locks in both directions)
Series			FSE - locks if pressure drops
Mounting			See dimensional drawing
Connection			Threaded
Ambient Temperature	J _{max}	°F(C)	176° (+80) Note: When using below freezing point (0°C) it is necessary to consult us
Medium Temperature	J _{max}	°F(C)	176° (+80)
Weight (mass)		lb(kg)	See table below
Installation Position			Optional
Medium			Filtered and regulated compressed air
Lubrication			Oil mist lubrication compatible with NBR seals
Material			
Cartridge			Aluminum
Housing			Aluminum
Clamping Jaw			Bronze
Cyl. piston rod			Stainless Steel
Pneumatic Characteristics			
Nominal Pressure	P _n	PSI(bar)	90 (6)
Cylinder Operating Pressure	P _{min}	PSI(bar)	15 (1)
	P _{max}	PSI(bar)	145 (10)
Lock Release Pressure		PSI(bar)	≥60 - 145 (≥4 - 10)
Static Locking Force		lbf	135 225 337 495 674 1124 1574
		N	600 1000 1500 2200 3000 5000 7000
Cylinder Diameter		mm	32 40 50 63 80 100 125
Connection Size			G1/8 G1/4 G1/4 G3/8 G3/8 G1/2 G1/2
Piston Rod Diameter		mm	12 16 20 20 25 25 32
Piston Rod Extension		mm	43 46 56 56 78 78 111
Pilot Air Connection			M5 M5 G1/8 G1/8 G1/8 G1/8 G1/8

Weight		Cylinder Diameter (mm)							
Description		32	40	50	63	80	100	125	
Blocking Unit	lbs.	1.32	1.76	2.20	2.65	3.09	3.53	3.97	
	kg	0.60	0.80	1.00	1.20	1.40	1.60	1.80	
Basic cylinder with 100mm stroke and rod extension	lbs.	1.54	2.65	3.86	5.12	8.27	10.80	17.35	
	kg	0.70	1.20	1.75	2.32	3.75	4.90	7.87	

Series FSE

Ø32mm - 125mm

Versions:

- Blocking Unit with cylinder
- Blocking Unit without cylinder

AZ 50./...-FSE

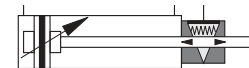

FSE..

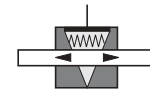

Blocking Unit holds the cylinder piston rod, if the signal pressure drops below 60 PSI (4 bar)

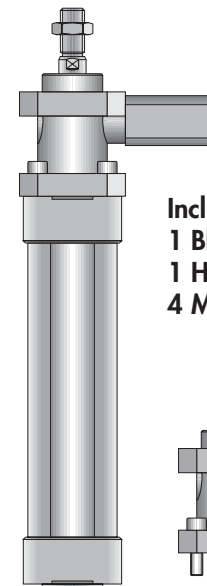

Includes:

- 1 Blocking Unit
- 1 Housing
- 4 Mounting Screws

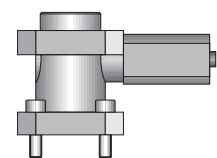

FSE Blocking Cylinder

Technical Information

Function

If the signal pressure (P) is removed, the piston rod (6) is locked by the two tilting plates (3 and 4).

The signal pressure (P) presses the piston (1) downward, pushing the two tilting plates (3 and 4) together. The piston rod (6) is then free to move. If the signal pressure (P) is removed from the piston chamber (5), the spring (2) pushes the two plates (3 and 4) apart. The wedge effect pushes the piston (1) upward, tilting the plates (3 and 4) apart and locking the piston rod (6).

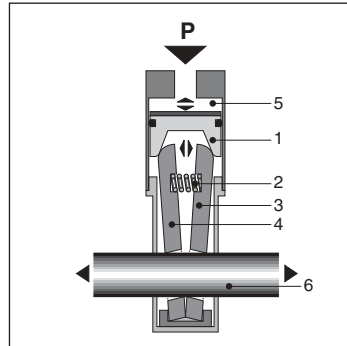

Important

- The Blocking Unit cannot be installed until the unit is unlocked, either by air pressure or by a suitable screw.
- When the cylinder piston rod is locked, it must not be rotated or subjected to external forces.

Circuit Diagrams for a Cylinder with an FSE Blocking Unit

Example 1: Horizontal Application with 5/3 Valve - RFB (dual center)

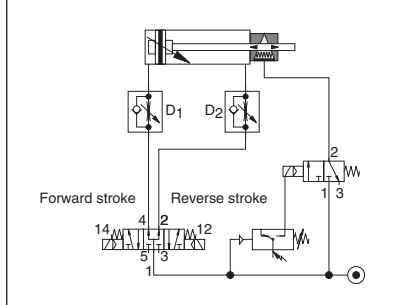

Example 2: Horizontal Application with 5/3 Valve - RFE (open center)

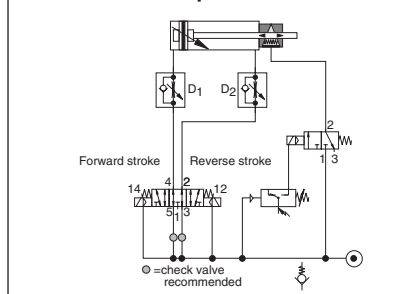

Example 3: Horizontal Application with Two 3/2 Valves

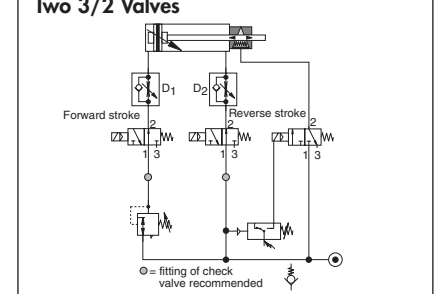

Examples 1 and 2:

When operating pressure is applied, the P/E converter is closed and the 3/2 valve is opened, i.e. the Blocking Unit is unlocked (working position).

The Blocking Unit is actuated with a 3/2 solenoid valve via a pressure switch. If the pressure drops, the pressure switch reacts and the Blocking Unit exhausts via the 3/2 way valve. The piston rod is locked. The use of the 5/3 valve ensures that both sides of the cylinder piston are pressurized. De-energizing the Blocking Unit allows the piston rod to remain in its present position.

Example 4: Vertical Application with 5/3 Valve - RFE (open center)

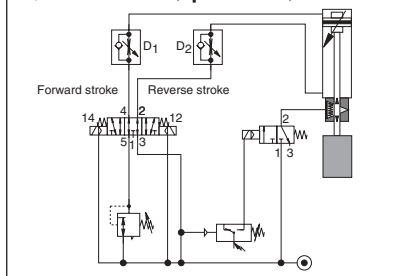

Example 5: Vertical Application with Two- 3/2 N/O Valves

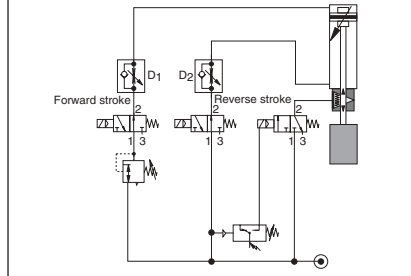

Without the Blocking Unit, the piston rod would continue its forward stroke because of the different piston areas. After the pressure is equalized on both sides of the cylinder piston, the Blocking Unit can be actuated and the piston rod locked. The sequence of operations must therefore be correct. The flow control valves, D1 and D2, only control piston speed and have no influence on the actuation of the Blocking Unit. Installing a check valve increases safety because it prevents any movement of the piston before the Blocking Unit locks.

Example 2:

An additional regulator is installed in port #5, to compensate for the effect of the different areas on the two sides of the piston.

Example 3:

In contrast to Examples 1 and 2, a 5/3 valve is replaced by two 3/2 valves. It is similar to the control solution in Example 2. The choice will depend on the customer and the particular application.

FSE Blocking Cylinder



Dimensional Details

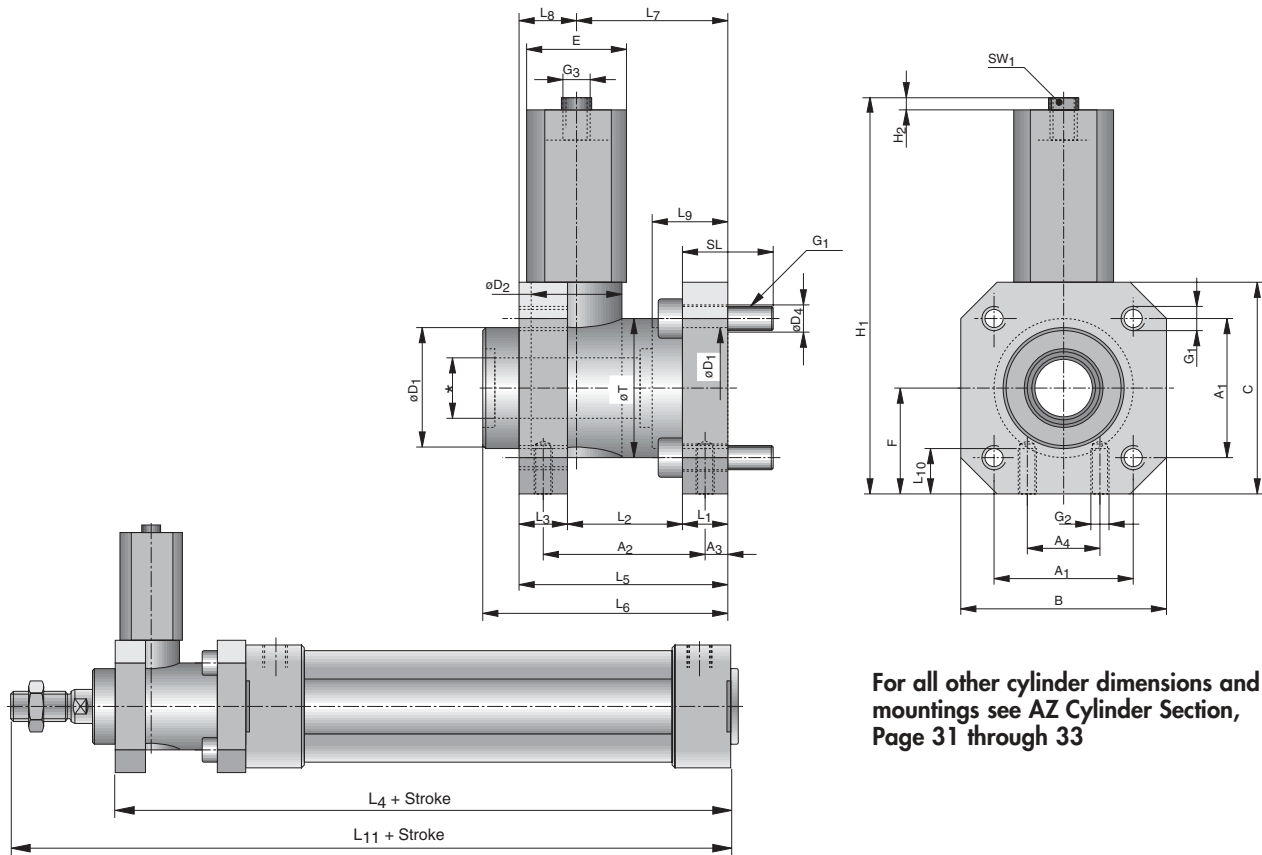

For all other cylinder dimensions and mountings see AZ Cylinder Section, Page 31 through 33

Bore Ø	A ₁	A ₂	A ₃	A ₄	B	C	øD ₁	øD ₂	øD ₄	E	F	G ₁	G ₂	G ₃	*	
32	1.28 32.5	1.57 40	0.17 4.2	0.63 16	1.89 48	1.97 50	1.18 30	0.79 20	0.26 6.6	0.89 22.7	0.98 25	M6	M5	M5	12	
40	1.50 38	1.81 46	0.18 4.5	0.83 21	2.20 56	2.28 58	1.38 35	0.94 24	0.26 6.6	1.09 27.7	1.14 29	M6	M5	M5	16	
50	1.83 46.5	2.13 54	0.45 11.5	0.94 24	2.68 68	2.76 70	1.57 40	1.18 30	0.33 8.5	1.29 32.7	1.38 35	M8	M6	G1/8	20	
63	2.22 56.5	2.17 55	0.30 7.5	1.26 32	3.23 82	3.35 85	1.77 45	1.50 38	0.33 8.5	1.61 41	1.67 42.5	M8	M8	G1/8	20	
80	2.83 72	2.76 70	0.39 10	1.73 44	3.94 100	4.13 105	1.77 45	1.57 40	0.43 11	1.96 49.7	2.07 52.5	M10	M8	G1/8	25	
100	3.50 89	2.76 70	0.39 10	2.36 60	4.72 120	5.12 130	2.17 55	1.89 48	0.43 11	2.15 54.7	2.56 65	M10	M8	G1/8	25	
125	4.33 110	3.74 95	0.43 11	2.95 75	5.51 140	5.91 150	2.36 60	2.56 65	0.51 13	2.56 64.9	2.95 75	M12	M10	G1/8	32	
Bore Ø	H ₁	H ₂	L ₁	L ₂	L ₃	L ₄ +Stroke	L ₅	L ₆	L ₇	L ₈	L ₉	L ₁₀	L ₁₁ +Stroke	SL	SW ₁	øT
32	3.78 96	0.16 4	0.31 8	1.10 28	0.47 12	5.59 142	1.89 48	2.28 58	1.26 32.0	0.63 16.0	0.81 20.5	0.31 8	7.21 183	0.79 20	8	1.34 34
40	4.09 104	0.16 4	0.39 10	1.30 33	0.47 12	6.30 160	2.17 55	2.56 65	1.40 35.5	0.77 19.5	0.89 22.5	0.39 10	8.08 205	0.99 25	8	1.65 42
50	5.00 127	0.16 4	0.59 15	1.54 39	0.63 16	6.93 176	2.76 70	3.23 82	1.93 49.0	0.83 21.0	1.16 29.5	0.47 12	9.09 231	1.18 30	13	1.97 50
63	5.96 151.5	0.16 4	0.59 15	1.58 40	0.59 15	7.53 191	2.76 7.0	3.23 82	1.93 49.0	0.83 21.0	1.16 29.5	0.47 12	9.69 246	1.18 30	13	1.97 50
80	7.17 182	0.16 4	0.63 16	2.28 58	0.63 16	8.47 215	3.55 90	4.33 110	2.44 62.0	1.10 28.0	1.40 35.5	0.63 16	11.50 292	1.18 30	17	2.36 60
100	8.15 207	0.16 4	0.63 16	2.28 58	0.71 18	9.06 230	3.62 92	4.53 115	2.56 65.0	1.06 27.0	1.52 38.5	0.63 16	12.09 307	1.18 30	17	2.36 60
125	8.94 227	0.16 4	0.98 25	2.76 70	1.06 27	11.11 282	4.81 122	6.07 154	3.35 85.0	1.46 37	1.79 45.5	0.79 20	15.13 384	1.77 45	17	3.15 80

FSE Blocking Unit

Ordering Details

Ordering Details for AZ Cylinder with FSE Blocking Unit

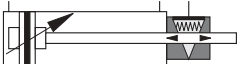
Description	Symbol	Bore Ø	Type #	Order #
Double acting, with adjustable cushions, magnetic piston, Blocking unit and rod extension		32mm	AZ5032/...-FSE	PA 58347-....
		40mm	AZ5040/...-FSE	PA 59267-....
		50mm	AZ5050/...-FSE	PA 60347-....
		63mm	AZ5063/...-FSE	PA 61287-....
		80mm	AZ5080/...-FSE	PA 62187-....
		100mm	AZ5100/...-FSE	PA 63087-....
		125mm	DZ 5125/...-FSE (M24x2)	PA 64017-....
		125mm	DZ 5125/...-FSE (M27x2)	PA 64027-....

Add stroke length (mm, 4 digits)

- Stroke lengths: any mm increment up to 500mm standard
- Contact factory for special stroke lengths

Ordering Details for FSE Blocking Unit (without cylinder)

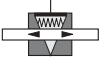
Description	Symbol	Bore Ø	Type #	Order #
Note: Requires cylinder with rod extension		32mm	FSE 032	KC 8227
		40mm	FSE 040	KC 8228
		50mm	FSE 050	KC 8229
		63mm	FSE 063	KC 8230
		80mm	FSE 080	KC 8231
		100mm	FSE 100	KC 8232
		125mm	FSE 125	KC 8233

Proximity Sensors/Brackets: See Page 73

FEU Linear Guide

Specifications

Series FEUG
Linear Guide, "U-Form"
 For cylinders conforming to
 ISO 6431/6432
 Ø8mm - 100mm

Features							
Installation		In any Position					
Temperature Range		Min. -4° F (-20° C) Max. +176° F (+80° C)					
Material							
Guide Body		Aluminium, Anodized					
Guide Rods		Stainless Steel					
Guide Bushing		Sintered Bronze					
Mounting Plate		Aluminium, Anodized					
Piston Rod Mounting		Stainless Steel					
Weight	Bore	ø8/10	ø12/16	ø20/25			
With 100mm Stroke	lbs. (kg)	0.44 (0.20)	0.84 (0.38)	1.50 (0.68)			
Per add. 100mm Stroke	lbs. (kg)	0.11 (0.05)	0.18 (0.08)	0.29 (0.13)			
Weight (mass)	Bore	ø32	ø40	ø50	ø63	ø80	ø100
With 100mm Stroke	lbs.	2.91	4.37	7.39	10.14	18.30	23.92
	kg	1.32	1.98	3.35	4.60	8.30	10.85
Per add. 100mm Stroke	lbs.	0.40	0.71	1.10	1.10	1.70	1.70
	kg	0.18	0.32	0.50	0.50	0.77	0.77

Maximum working load in relation to overhang - FEUG version with plain bearings

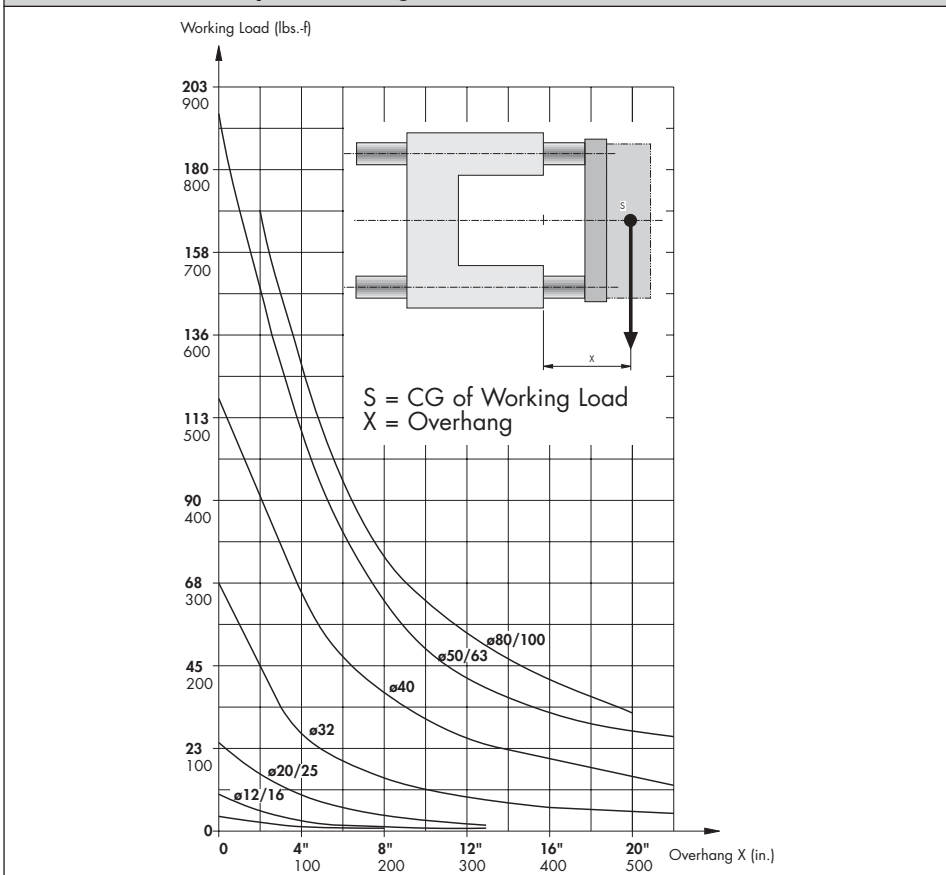

FEU Linear Guide

Ordering Information

Linear Guide, "U-Form"

Type: FEU

Example: Bore: Ø50mm
 Stroke: 160mm
 Type: FEUG 50/160
 Order No. PD 38019-0160

ISO 6432 Cylinders Plain Bearing: Type FEUG		8-10mm		12-16mm		20mm		25mm	
Bore Ø		FEUG 8-10/xx		FEUG 12-16/xx		FEUG 20/xx		FEUG 25/xx	
Type #		PD 38013-		PD 38014-		PD 38015-		PD 38016-	
Order #		PD 38013-		PD 38014-		PD 38015-		PD 38016-	
Strokes (MM)	(xx)								
25		0025	—	—	—	—	—	—	—
50		0050	0050	0050	0050	0050	0050	0050	0050
100		0100	0100	0100	0100	0100	0100	0100	0100
160		—	—	—	0160	0160	0160	0160	0160
200		—	0200	0200	0200	0200	0200	0200	0200
250		—	—	—	0250	0250	0250	0250	0250
320		—	—	—	0400	0400	0400	0400	0400

ISO 6431 Cylinders Plain Bearing: Type FEUG		32mm		40mm		50mm		63mm		80mm		100mm	
Bore Ø		FEUG 32/xx		FEUG 40/xx		FEUG 50/xx		FEUG 63/xx		FEUG 80/xx		FEUG 100/xx	
Type #		PD 38017-		PD 38018-		PD 38019-		PD 38020-		PD 38021-		PD 38022-	
Order #		PD 38017-		PD 38018-		PD 38019-		PD 38020-		PD 38021-		PD 38022-	
Strokes (MM)	(xx)												
50		0050	0050	0050	0050	0050	0050	0050	0050	0050	0050	0050	0050
100		0100	0100	0100	0100	0100	0100	0100	0100	0100	0100	0100	0100
160		0160	0160	0160	0160	0160	0160	0160	0160	0160	0160	0160	0160
200		0200	0200	0200	0200	0200	0200	0200	0200	0200	0200	0200	0200
250		0250	0250	0250	0250	0250	0250	0250	0250	0250	0250	0250	0250
320		0320	0320	0320	0320	0320	0320	0320	0320	0320	0320	0320	0320

Note: All units use metric mounting threads only.
 Contact factory for special stroke lengths.

Linear Guides Only: Corresponding Cylinders Need to be Ordered Separately!

FEU Linear Guide

Cylinder Details

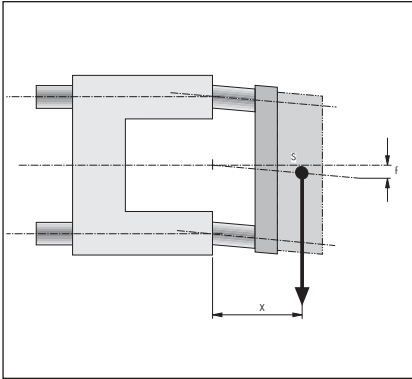

S = CG of working load
 X = Overhang
 f = Deflection

Deflection -FEUG version with plain bearings

Diagram 1 - Deflection with a working load of 23 lbs.

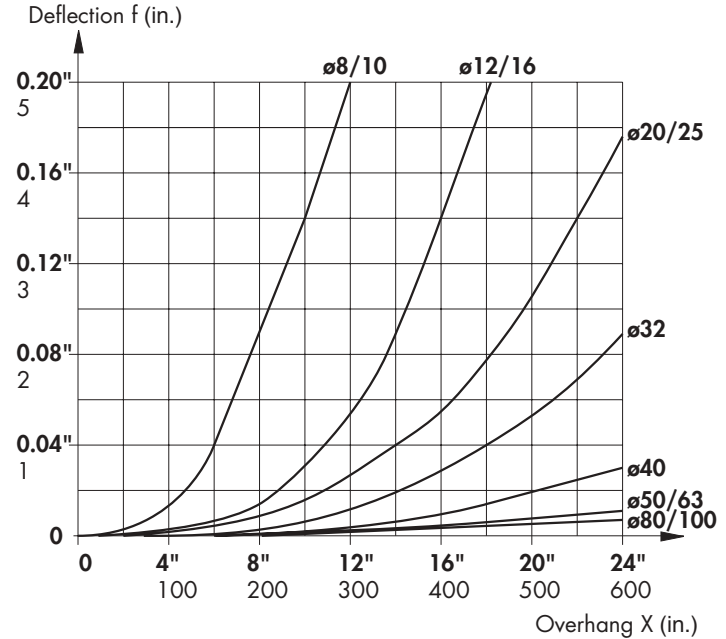

The total deflection is the sum of the deflection under own weight (Diagram 2) and the deflection under load (Diagram 1).
 The deflection for every 23 lb. load is shown in Diagram 1.

Diagram 2 - Deflection under own weight

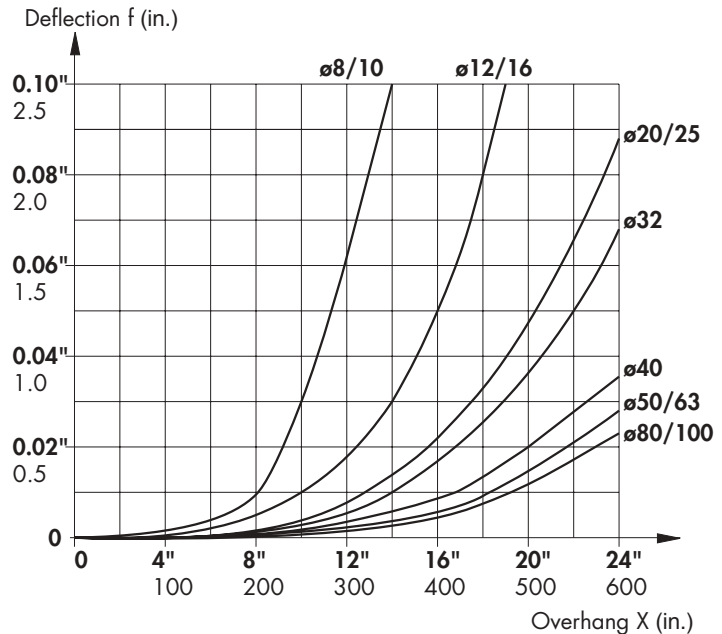

FEU Linear Guide

Dimensional Details

FEUG Ø8-25mm ISO 6432

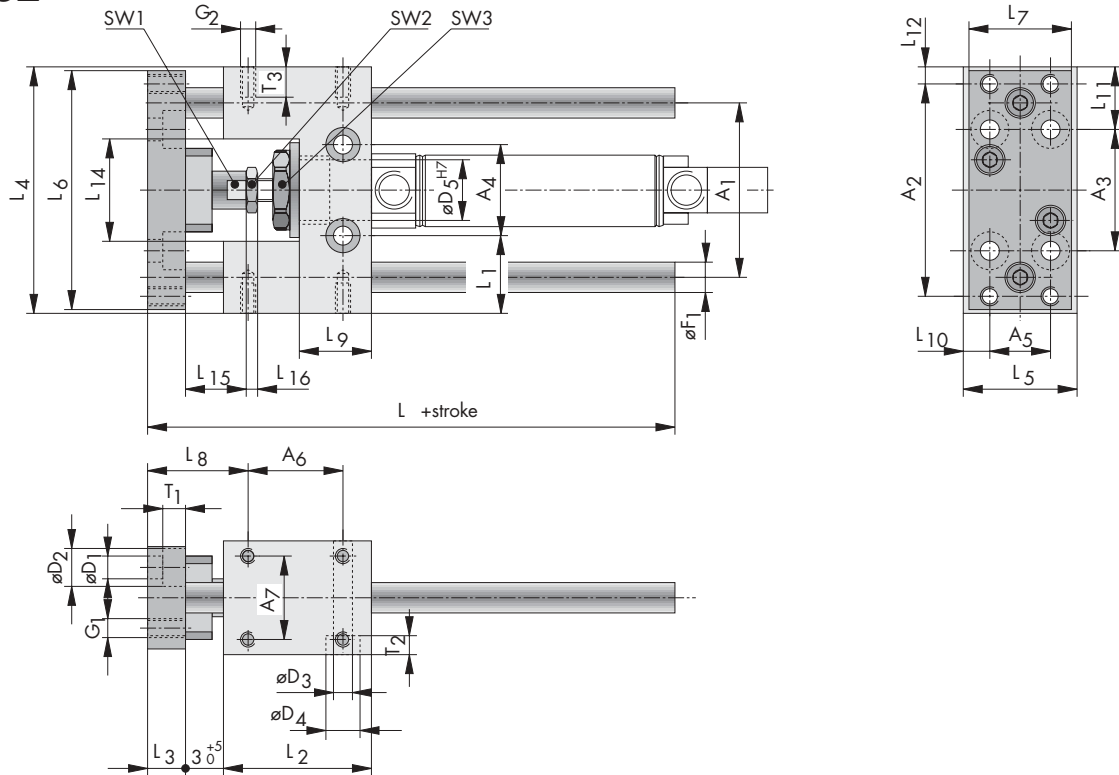

Bore Ø	A ₁	A ₂	A ₃	A ₄	A ₅	A ₆	A ₇	D ₁	D ₂	D ₃	D ₄	D ₅ ^{H7}	F ₁	G ₁	G ₂	L _{1+stroke}	L ₂	L ₃	L ₄
8	1.57	1.65	0.98	0.94	0.63	0.75	0.75	0.22	0.39	0.18	-	0.47	0.24			2.36	1.38	0.39	2.20
	40	42	25	24	16	19	19	5.5	10	4.5	-	12	6	M5	M4	60	35	10	56
10	1.57	1.65	0.98	0.94	0.63	0.75	0.75	0.22	0.39	0.18	-	0.47	0.24			2.36	1.38	0.39	2.20
	40	42	25	24	16	19	19	5.5	10	4.5	-	12	6	M5	M4	60	35	10	56
12	1.81	1.81	1.26	0.94	0.63	0.98	0.87	0.22	0.39	0.22	-	0.63	0.31			2.72	1.54	0.39	2.56
	46	46	32	24	16	25	22	5.5	10	5.5	-	16	8	M5	M4	69	39	10	65
16	1.81	1.81	1.26	0.94	0.63	0.98	0.87	0.22	0.39	0.22	-	0.63	0.31			2.72	1.54	0.39	2.56
	46	46	32	24	16	25	22	5.5	10	5.5	-	16	8	M5	M4	69	39	10	65
20	2.28	2.68	1.57	1.50	0.79	1.28	0.91	0.22	0.39	0.26	0.43	0.87	0.39			3.35	2.17	0.47	3.11
	58	68	40	38	20	32.5	23	5.5	10	6.6	11	22	10	M5	M6	85	55	12	79
25	2.28	2.68	1.57	1.50	0.79	1.28	0.91	0.22	0.39	0.26	0.43	0.87	0.39			3.35	2.17	0.47	3.11
	58	68	40	38	20	32.5	23	5.5	10	6.6	11	22	10	M5	M6	85	55	12	79
Bore Ø	L ₅	L ₆	L ₇	L ₈	L ₉	L ₁₀	L ₁₁	L ₁₂	L ₁₃	L ₁₄	L ₁₅	L ₁₆	SW1	SW2	SW3	T ₁	T ₂	T ₃	
8	1.02	2.13	0.98	0.83	0.67	0.20	0.61	0.28	0.63	0.94	0.75	0.09				0.22	-	0.31	
	26	54	25	21 ⁺⁵ ₀	17	5	15.5	7	16	24	19	2.2	9	a	15	5.7	-	8	
10	1.02	2.13	0.98	0.83	0.67	0.20	0.61	0.28	0.63	0.94	0.75	0.09				0.22	-	0.31	
	26	54	25	21 ⁺⁵ ₀	17	5	15.5	7	16	24	19	2.2	9	a	15	5.7	-	8	
12	1.18	2.48	1.06	0.77	0.75	0.28	0.65	0.16	0.81	1.06	0.63	0.13				0.22	-	0.31	
	30	63	27	19.5 ⁺⁵ ₀	19	7	16.5	4	20.5	27	16	3.2	9	a	19	5.7	-	8	
16	1.18	2.48	1.06	0.77	0.75	0.28	0.65	0.16	0.81	1.06	0.63	0.13				0.22	-	0.31	
	30	63	27	19.5 ⁺⁵ ₀	19	7	16.5	4	20.5	27	16	3.2	9	a	19	5.7	-	8	
20	1.34	2.99	1.26	0.94	0.98	0.28	0.77	0.22	0.81	1.46	1.14	0.16				0.22	-	0.55	
	34	76	32	24 ⁺⁵ ₀	25	7	19.5	5.5	20.5	37	29	4	13	a	27	5.7	-	14	
25	1.34	2.99	1.26	0.94	0.98	0.28	0.77	0.22	0.81	1.46	0.91	0.24				0.22	0.28	0.55	
	34	76	32	24 ⁺⁵ ₀	25	7	19.5	5.5	20.5	37	23	6	13	a	27	5.7	7	14	

FEHG & FEHK Linear Guide

Specifications

Series FEHG & FEHK Linear Guide, "H-Form"

For cylinders conforming to
ISO 6431
Ø32mm - 100mm

Features							
Installation	In any Position						
Temperature Range	Min. -4° F (-20° C) Max. +176° F (+80° C)						
Material							
Guide Body	Aluminium, Anodized						
Guide Rods	Stainless Steel for FEHG Version Stainless Steel, Hardened for FEHK Version						
Guide Bushing	Sintered Bronze for FEHG Version Linear Ball Bearings for FEHK Version						
Mounting Plate	Aluminium, Anodized						
Piston Rod Mounting	Stainless Steel						
Weight (mass)	Bore	ø32	ø40	ø50	ø63	ø80	ø100
With 4" (100mm) Stroke	lbs. (kg)	3.13 (1.42)	4.96 (2.25)	8.38 (3.80)	11.13 (5.05)	20.24 (9.18)	25.01 (11.8)
Per add. 4" (100mm) Stroke	lbs. (kg)	0.40 (0.18)	0.62 (0.28)	1.21 (0.55)	1.21 (0.55)	1.70 (0.77)	1.70 (0.77)

Maximum working load in relation to overhang - FEHG version with plain bearings

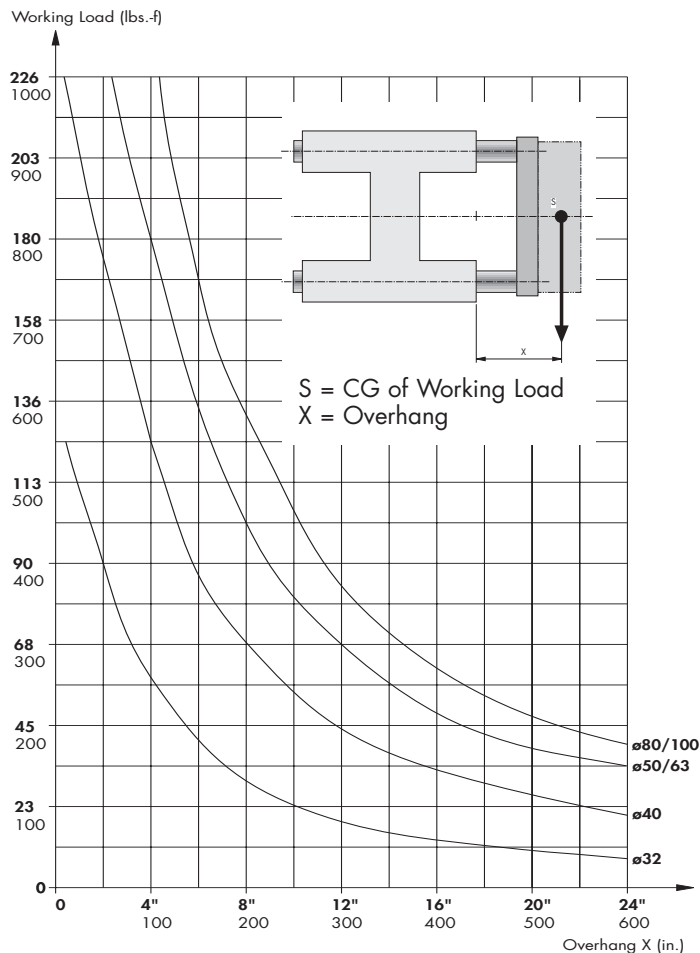

FEHG & FEHK Linear Guide

Ordering Information

Linear Guide, "H-Form"

Type: FEH

Example: Bore: Ø50mm
 Stroke: 160mm
 Type: FEHG 50/160
 Order No. PD 38003-0160

ISO 6431 Cylinders Plain Bearing: Type HG		32mm	40mm	50mm	63mm	80mm	100mm
Bore Ø		FEHG 32/xx	FEHG 40/xx	FEHG 50/xx	FEHG 63/xx	FEHG 80/xx	FEHG 100/xx
Type #							
Order #		PD 38001-	PD 38002-	PD 38003-	PD 38004-	PD 38005-	PD 38006-
Strokes (MM)							
50		0050	0050	0050	0050	0050	0050
100		0100	0100	0100	0100	0100	0100
160		0160	0160	0160	0160	0160	0160
200		0200	0200	0200	0200	0200	0200
250		0250	0250	0250	0250	0250	0250
320		0320	0320	0320	0320	0320	0320

ISO 6431 Cylinders Roller Bearing: Type HK		32mm	40mm	50mm	63mm	80mm	100mm
Bore Ø		FEHK 32/xx	FEHK 40/xx	FEHK 50/xx	FEHK 63/xx	FEHK 80/xx	FEHK 100/xx
Type #							
Order #		PD 38007-	PD 38008-	PD 38009-	PD 38010-	PD 38011-	PD 38012-
Strokes (MM)							
50		0050	0050	0050	0050	0050	0050
100		0100	0100	0100	0100	0100	0100
160		0160	0160	0160	0160	0160	0160
200		0200	0200	0200	0200	0200	0200
250		0250	0250	0250	0250	0250	0250
320		0320	0320	0320	0320	0320	0320

Note: All units use metric mounting threads only.
 Contact factory for special stroke lengths.

Linear Guides Only: Corresponding Cylinders Need to be Ordered Separately!

FEHG & FEHK Linear Guide

Cylinder Details

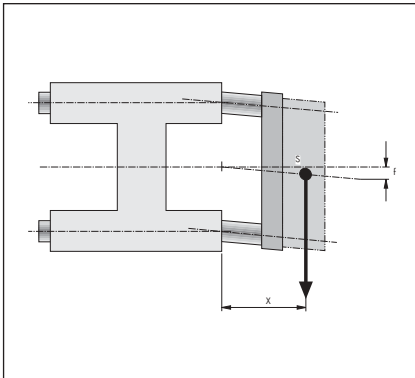

S = CG of working load
 X = Overhang
 f = Deflection

Deflection

-FEHG version with plain bearings and FEHK version with ball bearings

Diagram 1 - Deflection with a working load of 23 lbs.

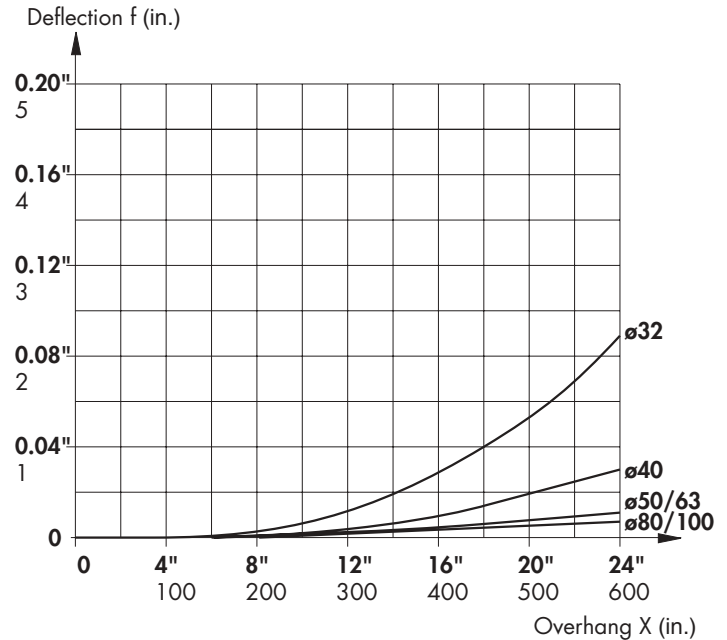

The total deflection is the sum of the deflection under own weight (Diagram 2) and the deflection under load (Diagram 1).
 The deflection for every 23 lb. load is shown in Diagram 1.

Diagram 2 - Deflection under own weight

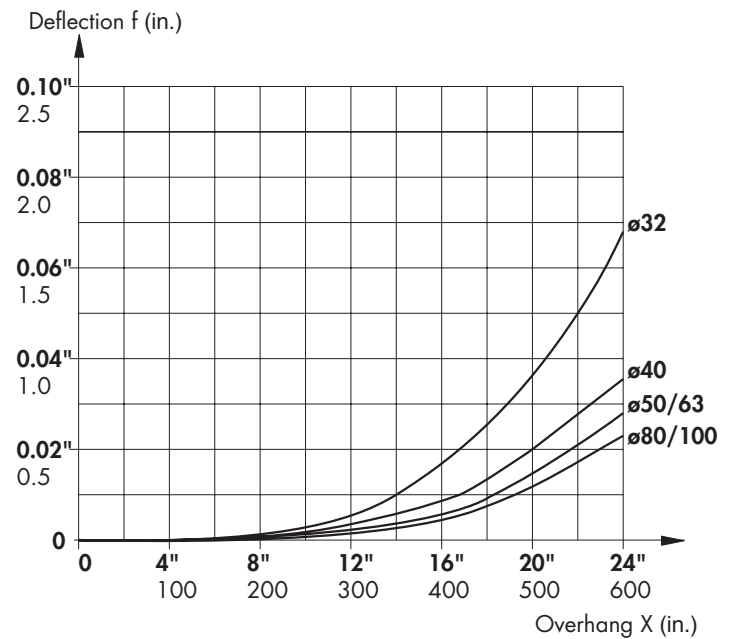

FEHG & FEHK Linear Guide

Cylinder Details

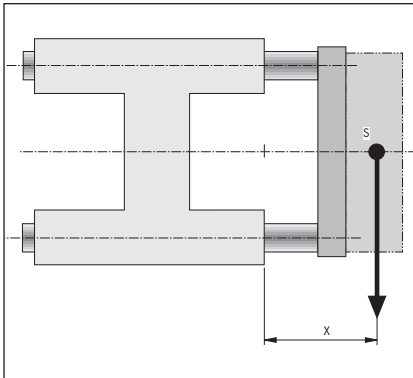

S = CG of working load
X = Overhang

Maximum working load in relation to overhang -FEHK version with ball bearings

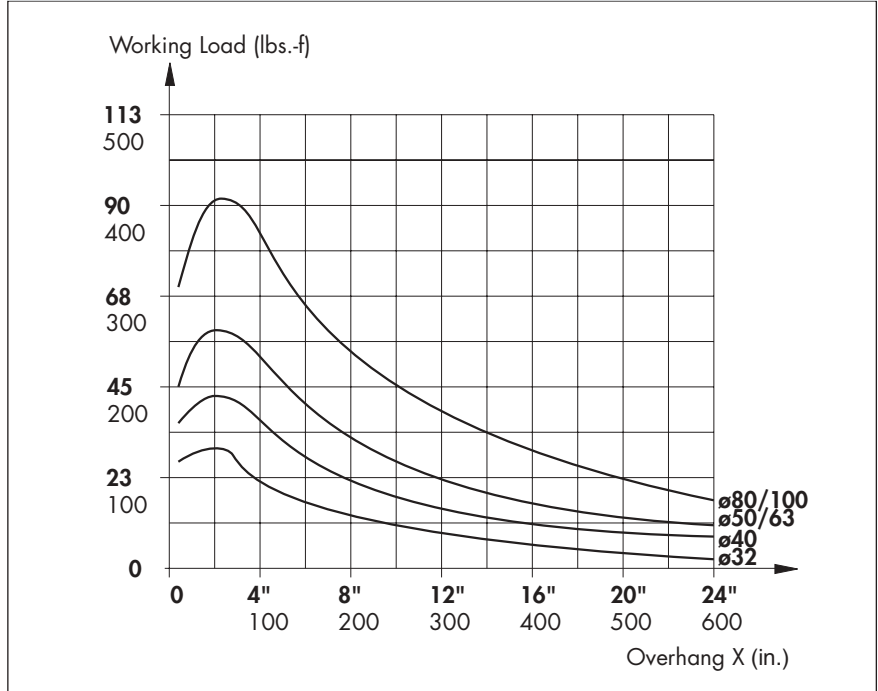

For short strokes, the working load figures obtained from the diagrams must be multiplied by a correction factor (k) (See Diagram).

In the working load curves for overhangs up to 60mm these short stroke corrections are already included.

In the case of impact loads, the maximum permissible working load must be halved.

Reduction of working load with short strokes -FEHK version with ball bearings

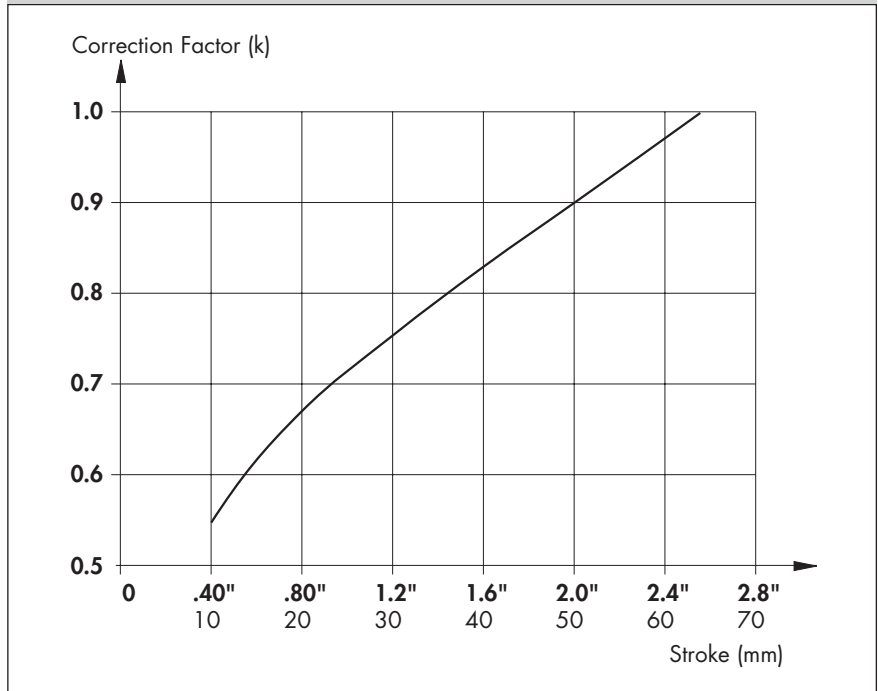

FEHG & FEHK Linear Guide

Dimensional Details

FEHG & FEHK Ø32-100mm ISO 6431

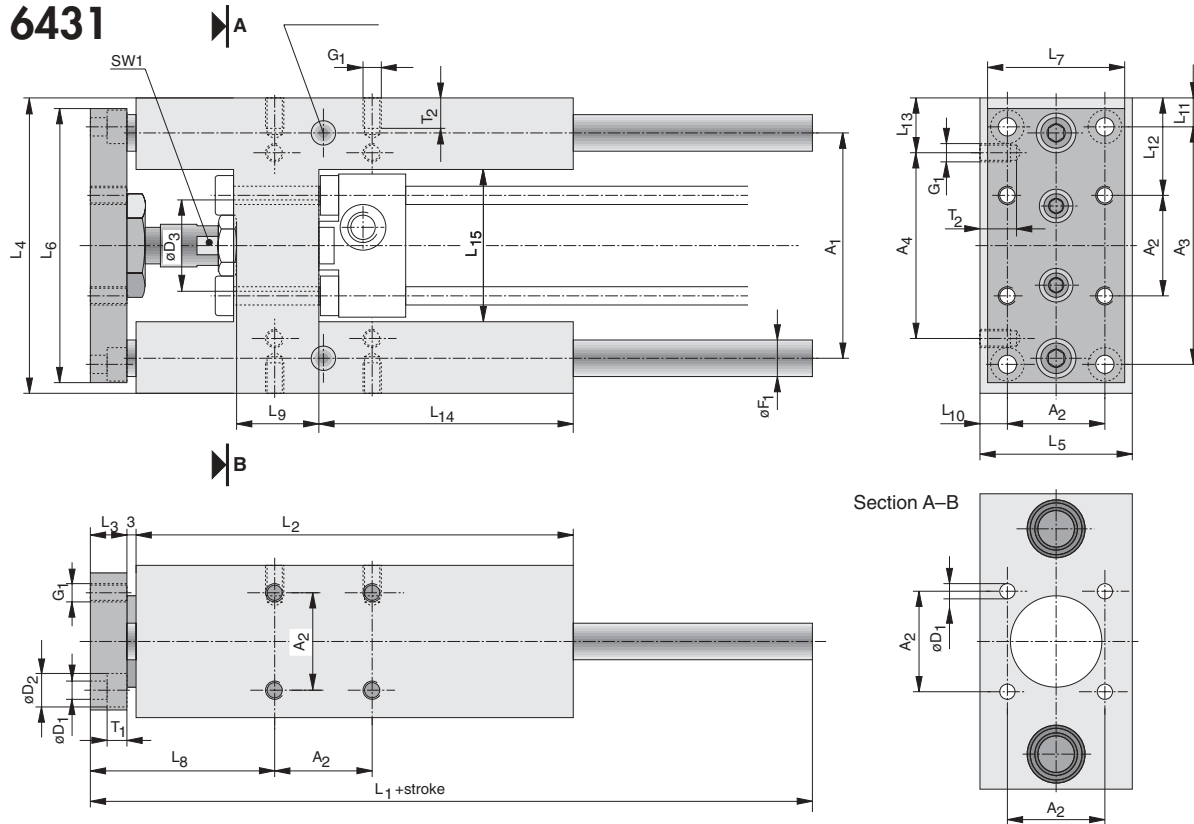

Bore Ø	A ₁	A ₂	A ₃	A ₄	D ₁	D ₂	D ₃	F ₁		G ₁	L _{1+stroke}	L ₂	L ₃	L ₄	L ₅
								HG	HK						
32	2.91	1.28	3.07	2.4	0.26	0.43	1.18	0.55	(0.47)	M6	6.97	4.09	0.47	3.82	1.97
	74	32.5	78	61	6.6	11	30	14	(12)		177	104	12	97	50
40	3.43	1.5	3.31	2.72	0.26	0.43	1.38	0.70	(0.63)	M6	7.56	4.80	0.47	4.53	2.28
	87	38	84	69	6.6	11	35	18	(16)		192	122	12	115	58
50	4.09	1.83	3.94	3.35	0.35	0.59	1.57	0.87	(0.79)	M8	9.33	5.71	0.59	5.39	2.76
	104	46.5	100	85	9	15	40	22	(20)		237	145	15	137	70
63	4.69	2.22	4.13	3.94	0.35	0.59	1.77	0.87	(0.79)	M8	9.33	6.30	0.59	5.98	3.35
	119	56.5	105	100	9	15	45	22	(20)		237	160	15	152	85
80	5.83	2.83	5.12	5.12	0.43	0.71	1.77	0.98		M10	11.02	8.46	0.79	7.44	4.13
	148	72	130	130	11	18	45	25			280	215	20	189	105
100	6.77	3.5	5.91	5.91	0.43	0.71	2.17	0.98		M10	11.02	8.66	0.79	8.39	5.12
	172	89	150	150	11	18	55	25			280	220	20	213	130
Bore Ø	L ₆	L ₇	L ₈	L ₉	L ₁₀	L ₁₁	L ₁₂	L ₁₃	L ₁₄	L ₁₅	SW1	SW2	T ₁	T ₂	
32	3.54	1.77	2.35	1.1	0.34	0.37	1.27	0.71	1.73	1.99				0.26	0.39
	90	45	59.7	28	8.75	9.5	32.25	18	44	50.5	13	-	6.5	10	
40	4.33	2.13	2.48	1.3	0.39	0.61	1.52	0.91	2.01	2.30				0.26	0.39
	110	54	63	33	10	15.5	38.5	23	51	58.5	15	-	6.5	10	
50	5.12	2.48	2.76	1.57	0.46	0.73	1.78	1.02	2.36	2.78				0.35	0.51
	130	63	70.2	40	11.75	18.5	45.25	26	60	70.5	22	-	9	13	
63	5.71	3.15	2.89	1.57	0.56	0.93	1.88	1.02	2.95	3.37				8.35	0.51
	145	80	73.5	40	14.25	23.5	47.75	26	75	85.5	22	-	9	13	
80	7.09	3.94	3.5	1.34	0.65	1.16	2.3	1.16	5.04	4.15				0.43	0.63
	180	100	89	34	16.5	29.5	58.5	29.5	128	105.4	27	30	11	16	
100	7.87	4.72	3.56	1.54	0.81	1.24	2.44	1.24	5.04	5.13				0.43	0.63
	200	120	90.5	39	20.5	31.5	62	31.5	128	130.4	27	30	11	16	