

Technical Information



Force and Load Charts - All Cylinders (except ROV)

Piston Area	Bore													
	8	10	12	16	20	25	32	40	50	63	80	100	125	
A IN ²	0.078	0.122	0.175	0.311	0.487	0.761	1.246	1.947	3.043	4.831	7.791	12.174	19.021	
B IN ²	0.059	0.101	0.132	0.264	0.403	0.636	1.07	1.643	2.558	4.34	7.037	11.408	17.779	
Theoretical Forces lbf at ___PSI														
PSI	15	1.17	1.83	2.63	4.67	7.31	11.42	18.69	29.21	45.65	72.47	116.87	182.61	285.32
	30	2.34	3.66	5.25	9.33	14.61	22.83	37.38	58.41	91.29	144.93	233.73	365.22	570.63
	45	3.51	5.49	7.88	14.00	21.92	34.25	56.07	87.62	136.94	217.40	350.60	547.83	855.95
	60	4.68	7.32	10.50	18.66	29.22	45.66	74.76	116.82	182.58	289.86	467.46	730.44	1141.26
	75	5.85	9.15	13.13	23.33	36.53	57.08	93.45	146.03	228.23	362.33	584.33	913.05	1426.58
	90	7.02	10.98	15.75	27.99	43.83	68.49	112.14	175.23	273.87	434.79	701.19	1095.66	1711.89
	105	8.19	12.81	18.38	32.66	51.14	79.91	130.83	204.44	319.52	507.26	818.06	1278.27	1997.21
	120	9.36	14.64	21.00	37.32	58.44	91.32	149.52	233.64	365.16	579.72	934.92	1460.88	2282.52
	135	10.53	16.47	23.63	41.99	65.75	102.74	168.21	262.85	410.81	652.19	1051.79	1643.49	2567.84
	150	11.70	18.30	26.25	46.65	73.05	114.15	186.90	292.05	456.45	724.65	1168.65	1826.10	2853.15

Piston Area	Bore													
	8	10	12	16	20	25	32	40	50	63	80	100	125	
A CM ²	0.502	0.785	1.131	2.01	3.141	4.91	8.04	12.56	19.63	31.17	50.26	78.54	122.7	
A CM ²	0.38	0.65	0.85	1.70	2.60	4.10	6.90	10.60	16.50	28.00	45.40	73.60	114.7	
Theoretical Forces kN at ___bar														
BAR	1	0.005	0.007	0.01	0.018	0.028	0.044	0.072	0.112	0.175	0.279	0.450	0.703	1.099
	2	0.009	0.014	0.02	0.036	0.056	0.088	0.144	0.225	0.351	0.558	0.900	1.407	2.199
	3	0.014	0.021	0.03	0.054	0.084	0.131	0.216	0.337	0.527	0.837	1.351	2.111	3.298
	4	0.018	0.028	0.04	0.072	0.112	0.175	0.288	0.450	0.703	1.117	1.801	2.814	4.398
	5	0.023	0.035	0.05	0.090	0.140	0.219	0.360	0.563	0.879	1.396	2.251	3.518	5.497
	6	0.027	0.042	0.06	0.108	0.168	0.263	0.432	0.675	1.055	1.675	2.702	4.222	6.597
	7	0.032	0.049	0.07	0.126	0.197	0.307	0.504	0.788	1.231	1.955	3.152	4.926	7.696
	8	0.036	0.056	0.08	0.144	0.225	0.351	0.576	0.900	1.407	2.234	3.603	5.629	8.796
	9	0.041	0.063	0.09	0.162	0.253	0.395	0.648	1.013	1.583	2.513	4.053	6.333	9.896
	10	0.045	0.070	0.10	0.180	0.281	0.439	0.720	1.125	1.759	2.793	4.503	7.037	10.995



- A* = PUSH- Piston area
- B* = PULL- Piston area minus rod

The figures shown above relate to the piston area, PUSH. The forces for the piston area minus the rod are not shown in the chart shown above.

Technical Information



Force and Load Charts - ROV Oval Bore

Bore Ø	Piston Rod	Actuation		Theoretical Forces													
				Area in ²	lbf at __ PSI						Area cm ²	da N at __ Bar					
					30	45	60	75	90	105		2	3	4	5	6	7
8	4	Double Acting	A*	0.10	3.00	4.50	6.00	7.50	9.00	10.50	0.63	1.26	1.89	2.52	3.15	3.78	4.41
			B*	0.08	2.40	3.60	4.80	6.00	7.20	8.40	0.51	1.02	1.53	2.04	2.55	3.06	3.57
		Single Acting	A**	0.10	3.00	4.50	6.00	7.50	9.00	10.50	0.63	0.63	1.13	1.77	2.52	3.15	3.78
			B**	0.08	2.40	3.60	4.80	6.00	7.20	8.40	0.51	0.42	0.93	1.44	1.95	2.46	2.97
10	4	Double Acting	A*	0.16	4.80	7.20	9.60	12.00	14.40	16.80	1.00	2.00	3.00	4.00	5.00	6.00	7.00
			B*	0.14	4.20	6.30	8.40	10.50	12.60	14.70	0.88	1.76	2.64	3.52	4.40	5.28	6.16
		Single Acting	A**	0.16	4.80	7.20	9.60	12.00	14.40	16.80	1.00	1.25	2.37	3.63	4.12	5.00	6.12
			B**	0.14	4.20	6.30	8.40	10.50	12.60	14.70	0.88	0.91	1.79	2.67	3.55	4.43	5.31
12	6	Double Acting	A*	0.23	6.90	10.35	13.80	17.25	20.70	24.15	1.50	3.00	4.50	6.00	7.50	9.00	10.50
			B*	0.19	5.70	8.55	11.40	14.25	17.10	19.95	1.23	2.46	3.69	4.92	6.15	7.38	8.61
		Single Acting	A**	0.23	6.90	10.35	13.80	17.25	20.70	24.15	1.50	2.44	4.08	5.40	6.88	8.37	10.12
			B**	0.19	5.70	8.55	11.40	14.25	17.10	19.95	1.23	1.61	2.84	4.07	5.30	6.53	7.76
16	6	Double Acting	A*	0.31	9.30	13.95	18.60	23.25	27.90	32.55	2.00	4.00	6.00	8.00	10.00	12.00	14.00
			B*	0.28	8.40	12.60	16.80	21.00	25.20	29.40	1.83	3.46	5.20	6.90	8.70	10.40	12.10
		Single Acting	A**	0.31	9.30	13.95	18.60	23.25	27.90	32.55	2.00	3.50	5.00	7.40	8.20	9.10	12.00
			B**	0.27	8.10	12.15	16.20	20.25	24.30	28.35	1.73	1.51	3.25	4.95	6.75	8.45	10.15
20	8	Double Acting	A*	0.59	17.70	26.55	35.40	44.25	53.10	61.95	3.80	7.60	11.40	15.20	19.00	22.80	26.60
			B*	0.51	15.30	22.95	30.60	38.25	45.90	53.55	3.30	6.60	9.90	13.20	16.50	19.80	23.10
		Single Acting	A**	0.59	17.70	26.55	35.40	44.25	53.10	61.95	3.80	4.63	8.78	4.63	15.98	19.52	24.15
			B**	0.51	15.30	22.95	30.60	38.25	45.90	53.55	3.30	3.70	5.88	10.30	13.60	16.90	20.20
25	10	Double Acting	A*	0.67	20.10	30.15	40.20	50.25	60.30	70.35	4.30	8.60	12.90	17.20	21.50	25.80	30.10
			B*	0.55	16.50	24.75	33.00	41.25	49.50	57.75	3.52	7.04	10.56	14.08	17.60	21.12	24.64
		Single Acting	A**	0.67	20.10	30.15	40.20	50.25	60.30	70.35	4.30	6.40	11.70	16.20	21.50	26.30	31.20
			B**	0.55	16.50	24.75	33.00	41.25	49.50	57.75	3.52	4.14	7.66	11.18	14.70	18.22	21.74



- A* = PUSH- Piston Area
- B* = PULL- Piston Area minus Rod
- A** = PUSH- Piston Area
- B** = PULL- Piston Area minus Rod & Spring

Technical Information

Force and Load Charts - ROV Oval Bore

For correct cylinder selection at full rod extension, Force "F" should be below the load curve on the appropriate cylinder chart.

LATERAL LOAD OFFSET

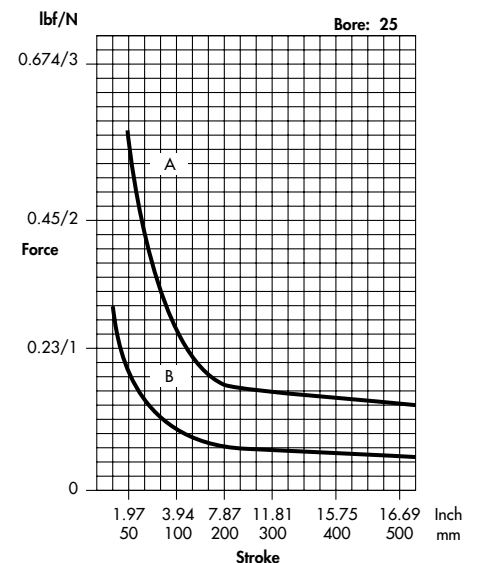
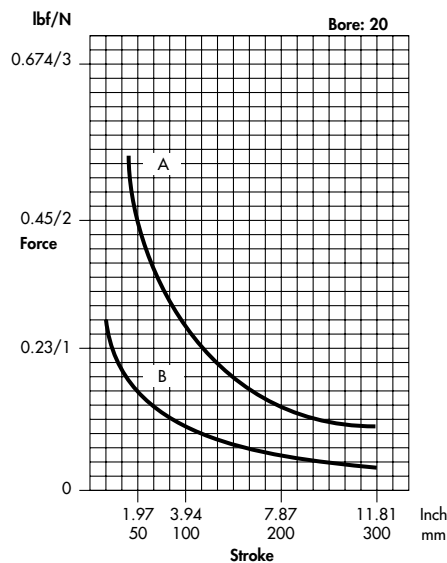
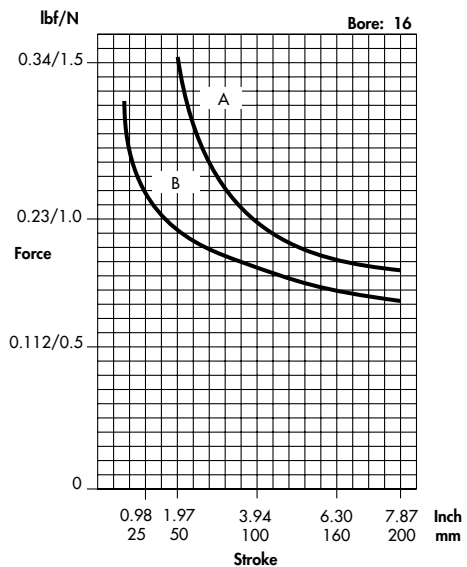
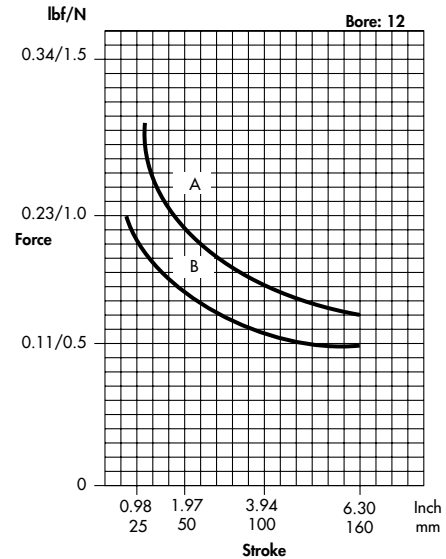
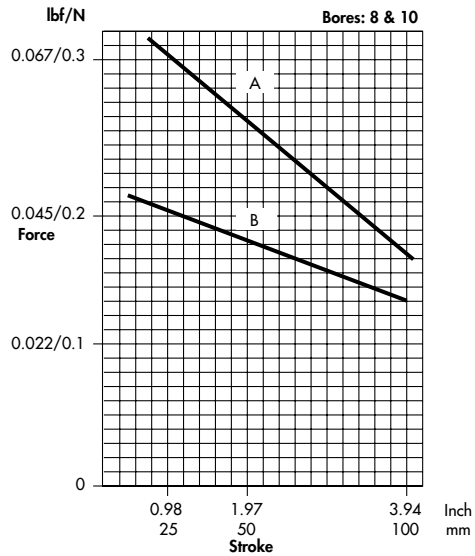
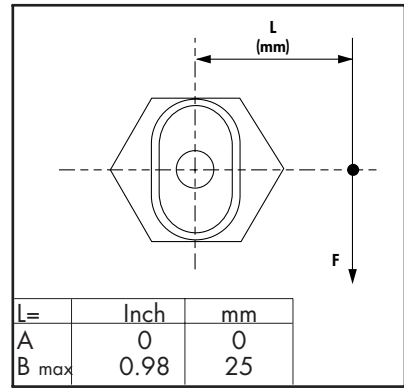

Technical Information



Force and Load Charts - AZV Twin Rod

Traverse Load Ø25-100mm

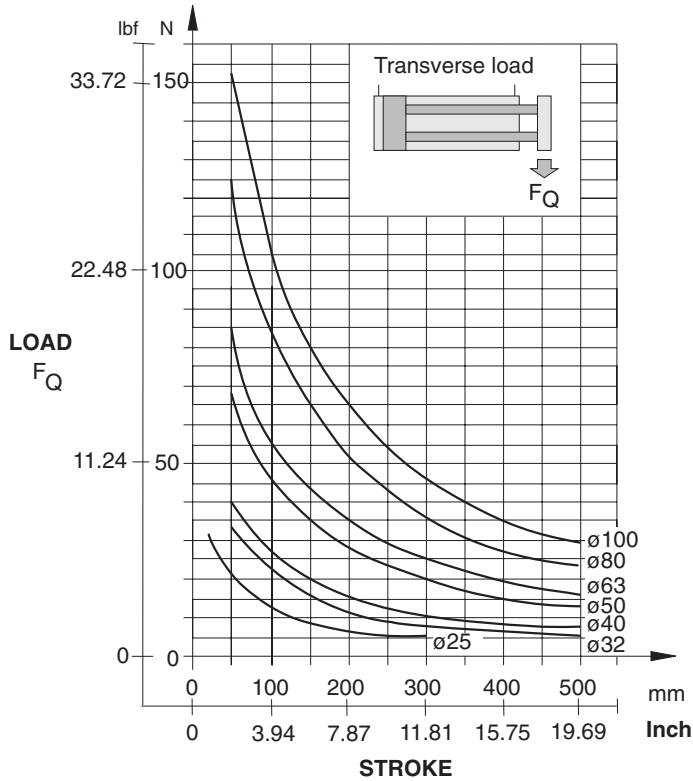

Torque Load Ø25-100mm

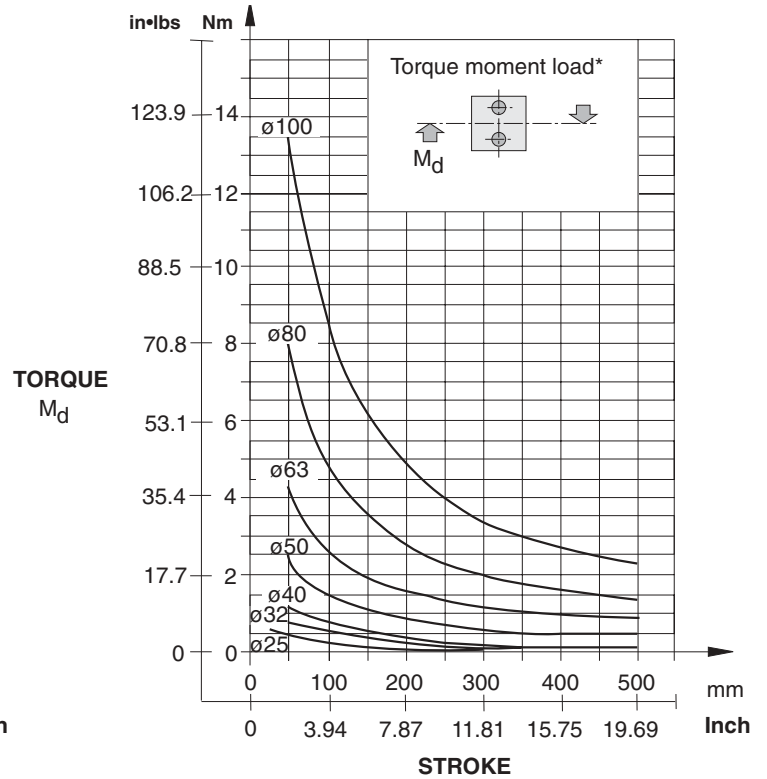

Side Load Ø25mm

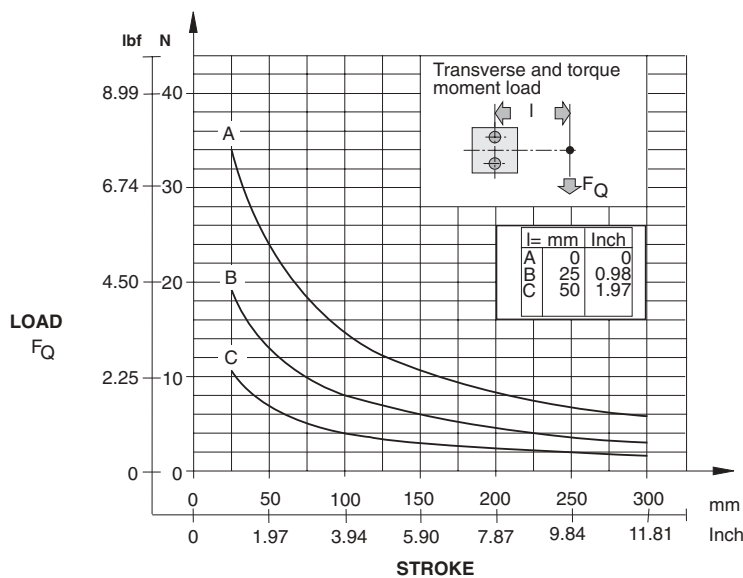

Side Load Ø32mm

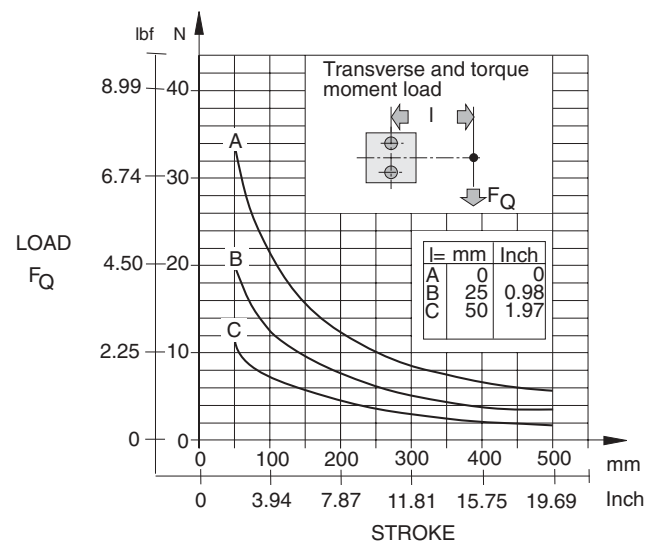

Technical Information

Force and Load Charts - AZV Twin Rod

Side Load Ø40mm

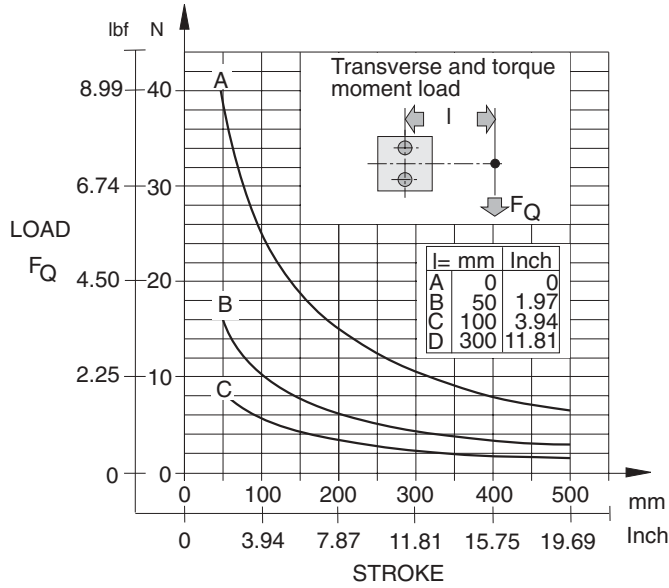

Side Load Ø50mm

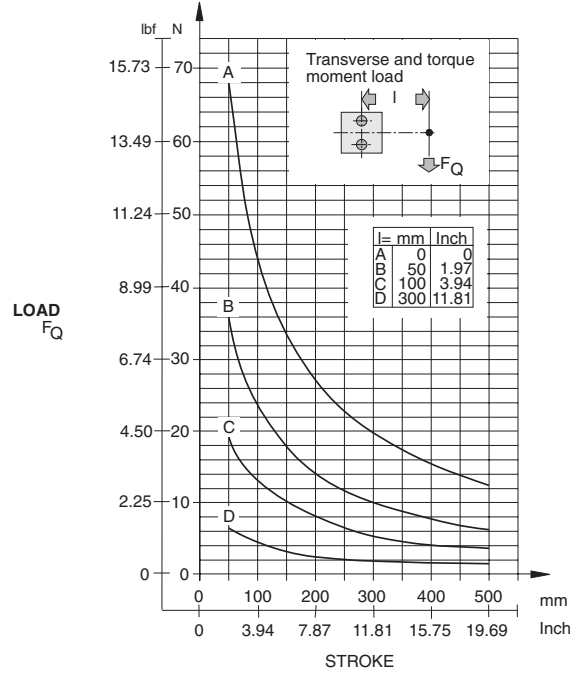

Side Load Ø63mm

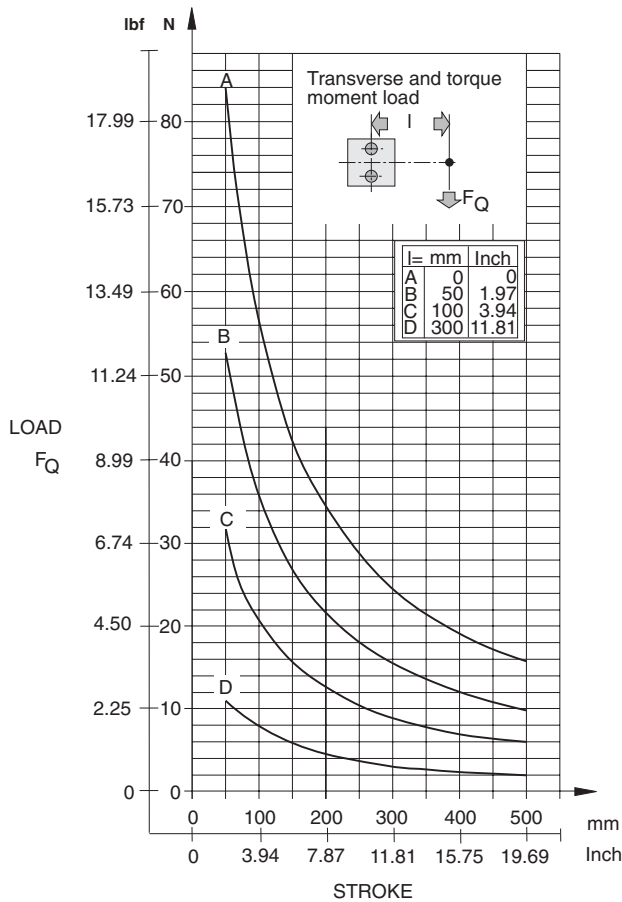

Side Load Ø80mm

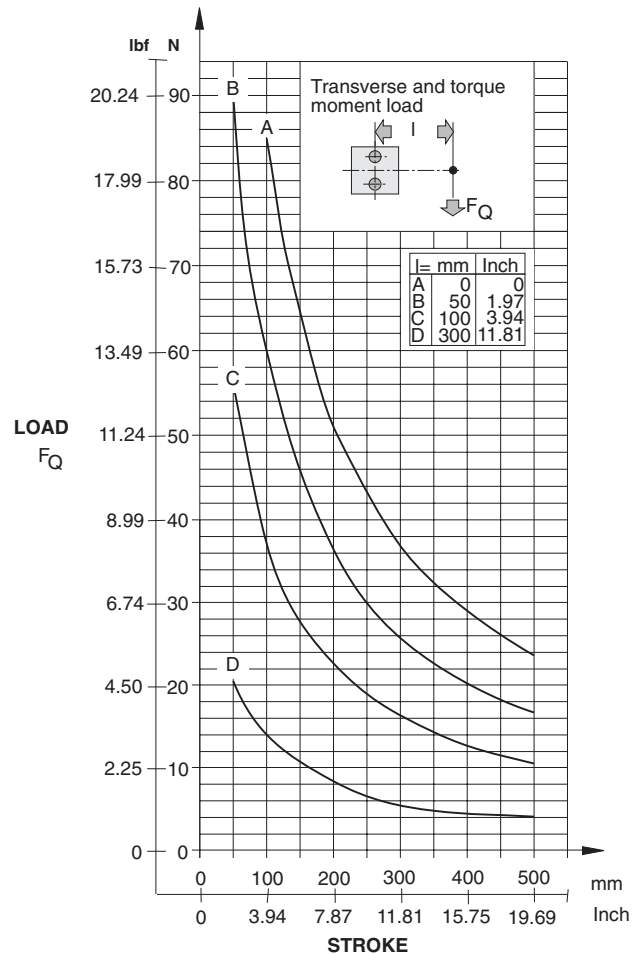

Technical Information

Force and Load Charts - AZV Twin Rod

Side Load $\varnothing 100\text{mm}$

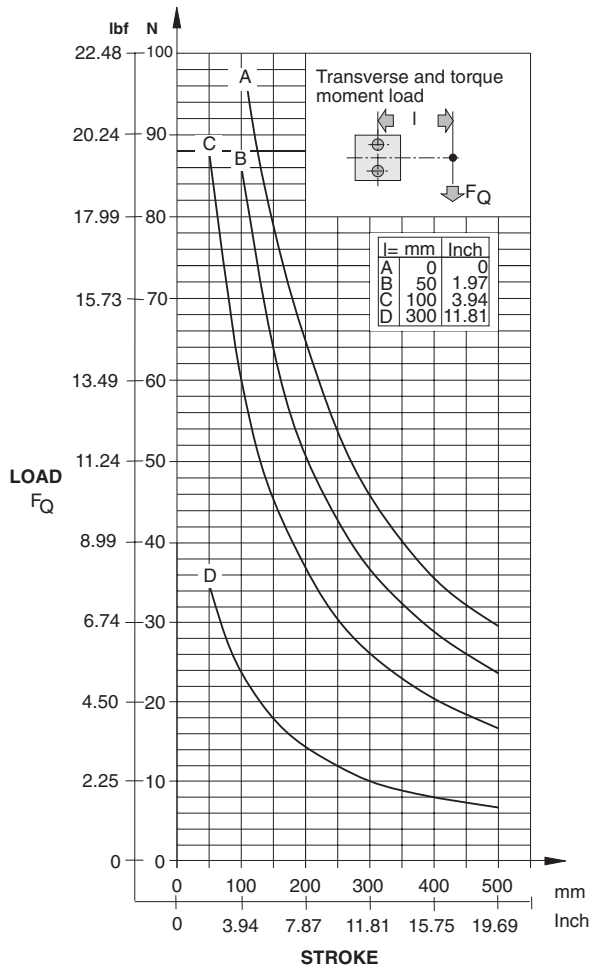

Recommended Installation

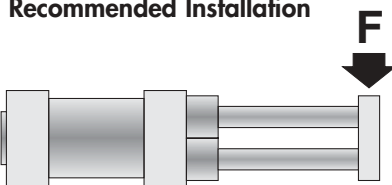

Cylinders should be mounted with the rods in the vertical orientation for optimum performance..