

Accessories for Linear Drive Systems (Mountings, Sensors) Series OSP-E Ballscrew

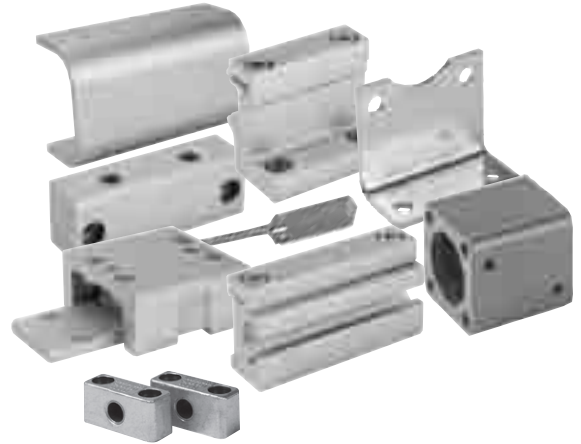

Contents

Description	Page
Clevis Mounting	92-93
End Cap Mountings	94
Mid-Section Support	95
End Cap Mountings (for Linear Drives with guides)	96-97
Mid-Section Support (for Linear Drives with guides)	98
Inversion Mounting	99
Adaptor Profile	100
T-Nut Profile	101
Profile Mountings	102

Linear Drive Accessories

Clevis Mounting

Size 25, 32, 50



- For Linear Drives
- Series OSP-E Belt
 - Series OSP-E Screw

When external guides are used, parallelism deviations can lead to mechanical strain on the piston. This can be avoided by the use of a clevis mounting. In the drive direction, the mounting has very little play. Freedom of movement is provided as follows:

- Tilting in direction of movement
- Vertical compensation
- Tilting sideways
- Horizontal compensation

A stainless steel version is also available.

Series OSP-E25 to E32

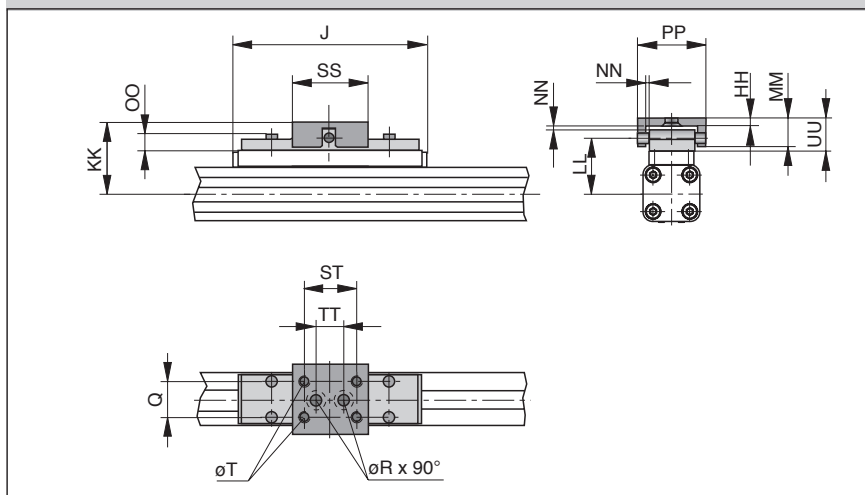

Series OSP-E50

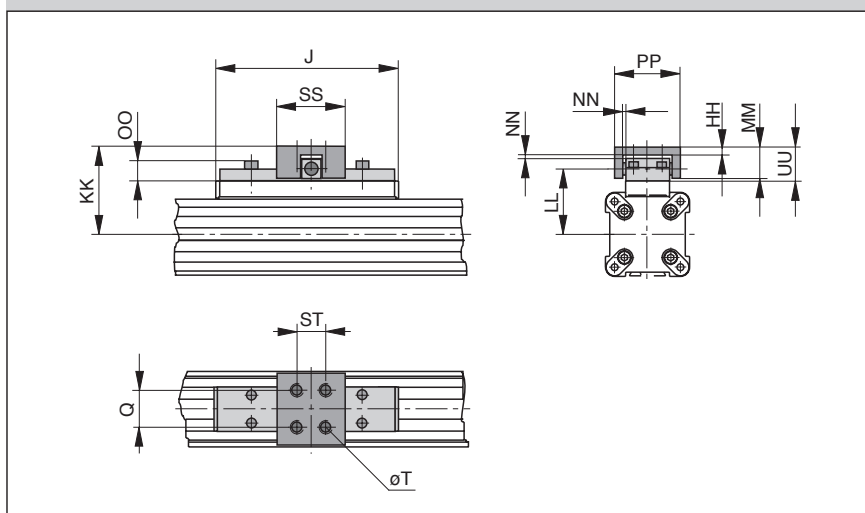

Dimension Table (mm)

Series	J	Q	T	øR	HH	KK	LL	MM	NN*	OO	PP	SS	ST	TT	UU	Order No.	
																Standard	Stainless
OSP-E25	117	16	M5	5.5	3.5	52	39	19	2	9	38	40	30	16	21	20005	20092
OSP-E32	152	25	M6	6.6	6	68	50	28	2	13	62	60	46	40	30	20096	20094
OSP-E50	200	25	M6	—	6	79	61	28	2	13	62	60	46	—	30	20097	20095

* Dimension NN gives the possible plus and minus play in horizontal and vertical movement, which also makes tilting sideways possible.

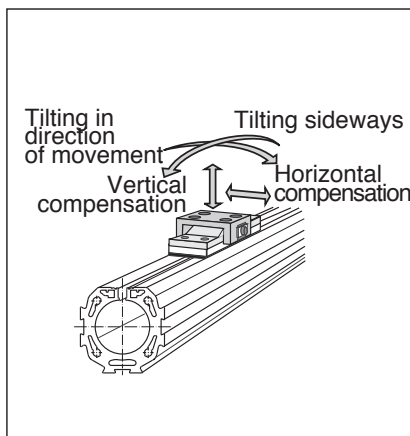

Please note:
When using additional inversion mountings, take into account the dimensions on page 99.

The right to introduce technical modifications is reserved

Series OSP-E25 to E32

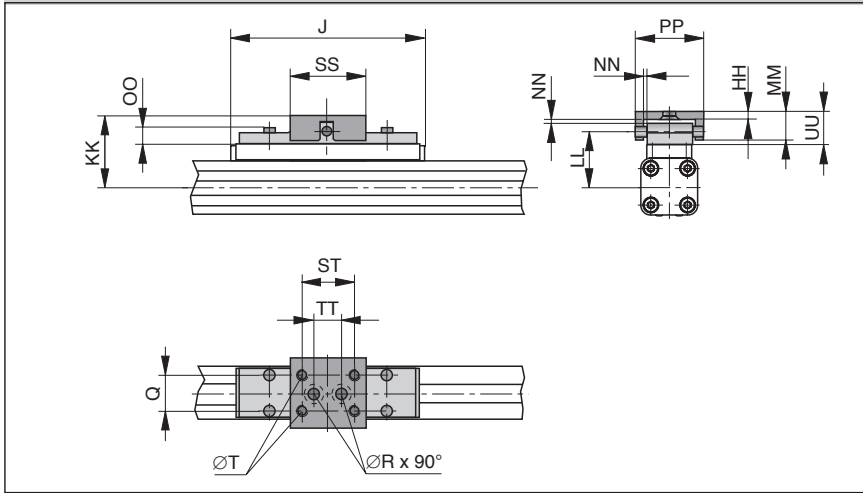

Linear Drive Accessories

Clevis Mounting, play-free

Size 25, 32, 50



- For Linear Drives
- Series OSP-E Belt
 - Series OSP-E Screw

Series OSP-E50

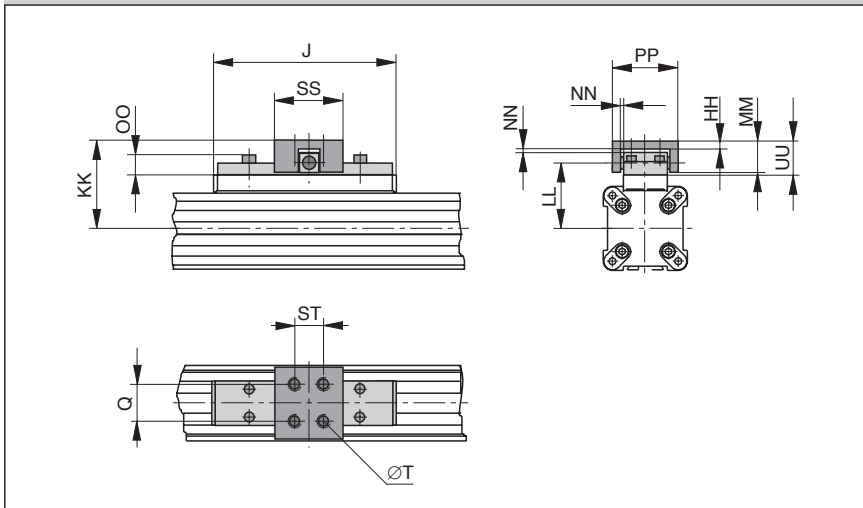

When external guides are used, parallelism deviations can lead to mechanical strain on the piston. This can be avoided by the use of a clevis mounting. In the drive direction the clevis mounting has a play-free fit.

Freedom of movement is provided as follows:

- Tilting in direction of movement
- Vertical compensation
- Tilting sideways
- Horizontal compensation

A stainless steel version is also available.

Dimension Table (mm)

Series	J	Q	T	øR	HH	KK	LL	MM	NN*	OO	PP	SS	ST	TT	UU	Order No.	
																Standard	Stainless
OSP-E25	117	16	M5	5.5	3.5	52	39	19	2	9	49	40	30	16	21	20496	20498
OSP-E32	152	25	M6	6.6	6	68	50	28	2	13	69	60	46	40	30	20497	20499
OSP-E50	200	25	M6	—	6	79	61	28	2	13	69	60	46	—	30	20812	20818

* Dimension NN gives the possible plus and minus play in horizontal and vertical movement, which also makes tilting sideways possible.

Please note:
When using additional inversion mountings, take into account the dimensions on page 99.

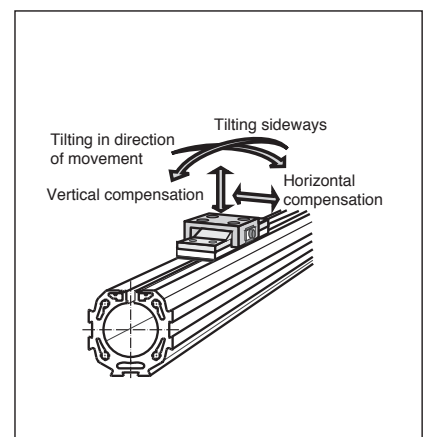
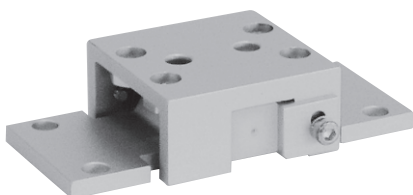

Linear Drive Accessories

End Cap Mountings

Size 25, 32, 50



For Linear Drive

- Series OSP-E Belt
- Series OSP-E Screw *

On the end-face of each end cap there are four threaded holes for mounting the actuator.

The hole layout is square, so that the mounting can be fitted to the bottom, top or either side.

Material:

Series OSP-25 to 32:

Galvanised steel.

Series OSP-50:

Anodized aluminium.

Series OSP-E25 to E32: Type A1

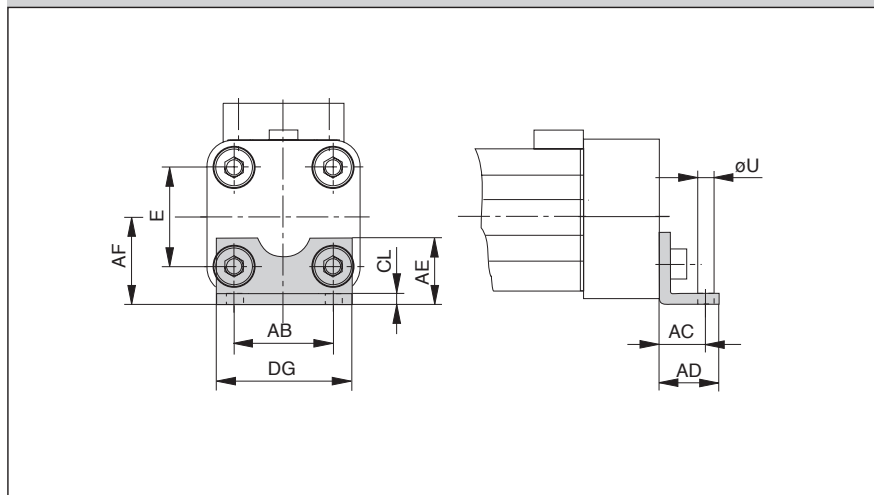

Series OSP-E50: Type C1

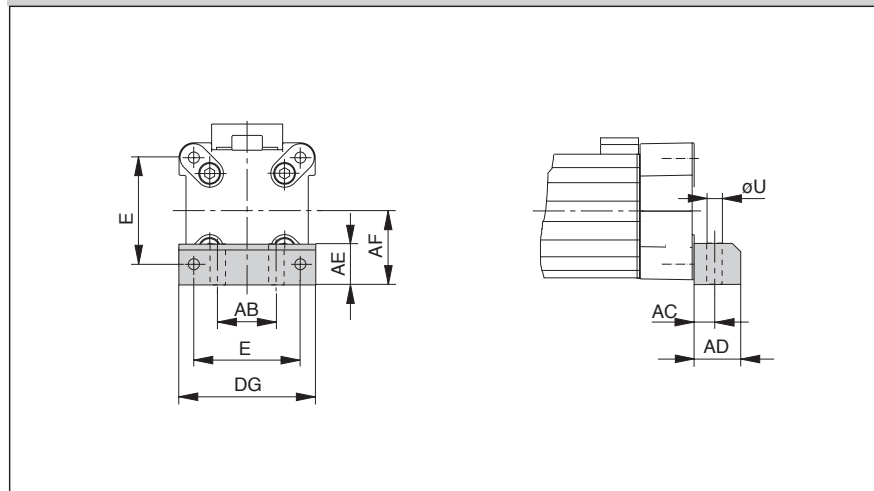

Dimension Table (mm)

Series	E	ØU	AB	AC	AD	AE	AF	CL	DG	Order No.	
										Type A1	Type C1
OSP-E25	27	5.8	27	16	22	18	22	2.5	39	2010-1	–
OSP-E32	36	6.6	36	18	26	20	30	3	50	3010-1	–
OSP-E50	70	9	40	12.5	24	30	48	–	86	–	5010-1

* Important:

With the OSP-E Screw series, the end cap mounting can only be used at the opposite end of the drive shaft.

We recommend the application of two mid section supports (page 95) at the drive shaft end of the actuator.

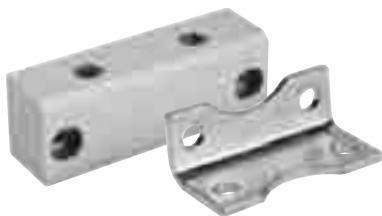

The right to introduce technical modifications is reserved

Series OSP-E25, E32, E50, Type E1
(Mounting from above / below with 2 through holes)

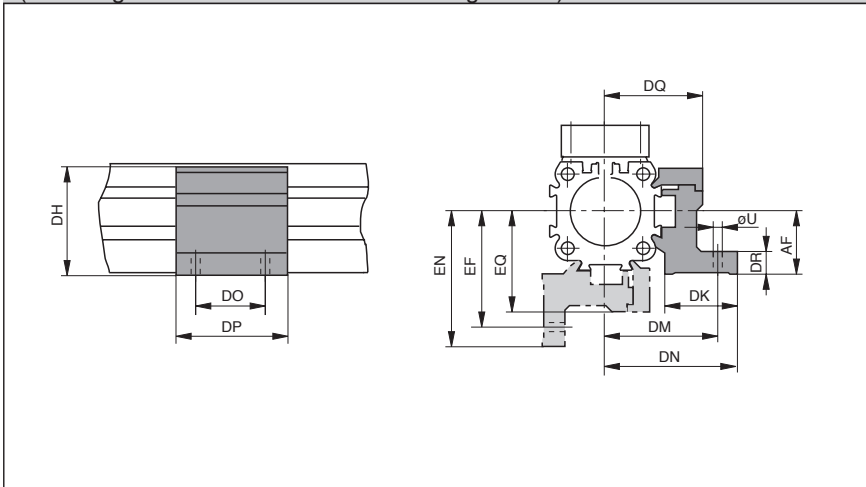

Series OSP-E25, E32, E50, Type D1
(Mountings from below with 2 screws)

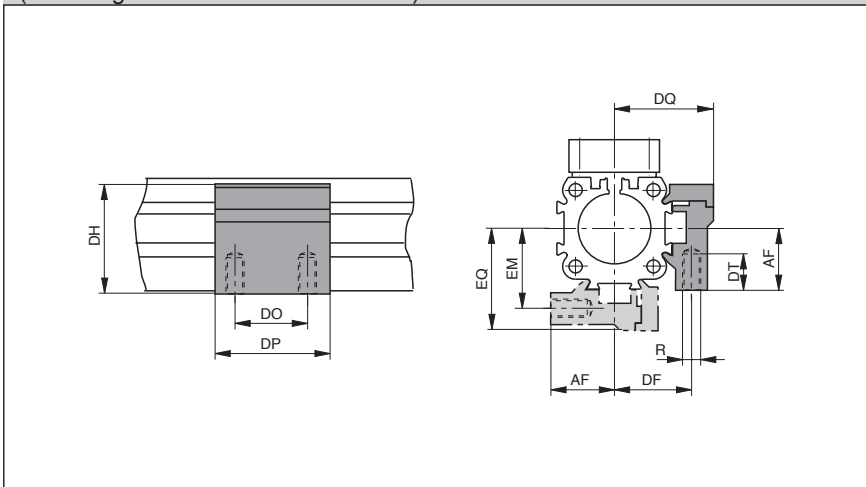

Linear Drive Accessories

Mid-Section Support

Size 25, 32, 50



For Linear Drive

- Series OSP-E Belt
- Series OSP-E Screw

Note on Types E1 and D1:
The mid-section support can also be mounted on the underside of the actuator, in which case its distance from the centre of the actuator is different.

Stainless steel version on request

Dimension Table (mm)

Series	R	U	AF	DF	DH	DK	DM	DN	DO	DP	DQ	DR	DT	EF	EM	EN	EQ	Order No.	
																		Type E1	Type D1
OSP-E25	M5	5.5	22	27	38	26	40	47.5	36	50	34.5	8	10	41.5	28.5	49	36	20009	20008
OSP-E32	M5	5.5	30	33	46	27	46	54.5	36	50	40.5	10	10	48.5	35.5	57	43	20158	20157
OSP-E50	M6	7	48	40	71	34	59	67	45	60	52	10	11	64	45	72	57	20163	20162

The right to introduce technical modifications is reserved







Linear Drive Accessories

Mountings for Linear Drives fitted with OSP-guides

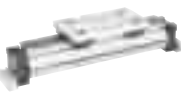

- For Linear Drive
- Series OSP-E Belt
 - Series OSP-E Screw *

Overview											
Mounting Type	Type	Type – OSP Guides									
		SLIDELINE PROLINE MULTIBRAKE			POWERSLIDE						
		25	32	50	25/ 25	25/ 35	25/ 44	32/ 35	32/ 44	50/ 60	50/ 76
End cap mounting 	Type A1										
	Type A2	O	O								
	Type A3				O	O		O			
End cap mounting, reinforced 	Type B1	X	X		X	X	X	X	X		
	Type B3										
	Type B4						O		O		
End cap mounting X 	Type C1			X						X	
	Type C2			O							
	Type C3									O	
	Type C4										O
Mid section support, small Mid section support, wide 	Type D1	X	X	X	X	X	X	X	X	X	X
	Type E1	X	X	X	X	X	X	X	X	X	X
	Type E2	O	O	O							
	Type E3				O	O		O		O	
	Type E4						O		O		O

- X = carriage mounted in top (12 o'clock position)
- O = carriage mounted in lateral (3 or 9 o'clock position)
-  = available components

*** Important:**
With the OSP-E Screw series, end cap mountings type A, B and C can only be used at the opposite end of the drive shaft. Please use mid-supports (page 98).

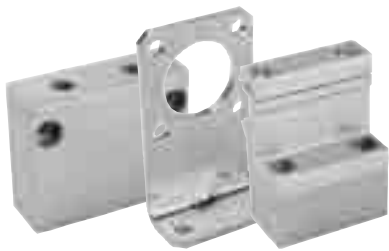

Series OSP – E25, E32: Type A

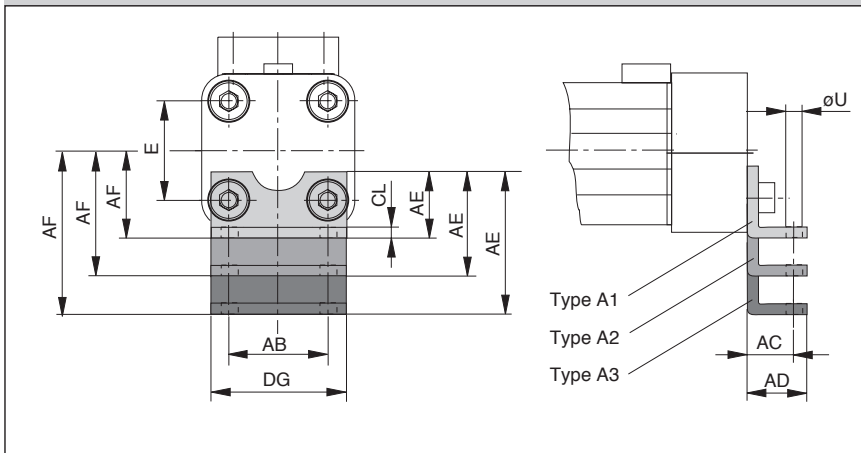

End cap mountings *

Four internal screw threads are located in the end faces of all OSP actuators for mounting the drive unit. End cap mountings may be secured across any two adjacent screws.

Material: Series OSP-25, 32: zinc plated steel
Series OSP-50: anodized aluminium

Supplied in pairs.

Series OSP – E25, E32: Type B

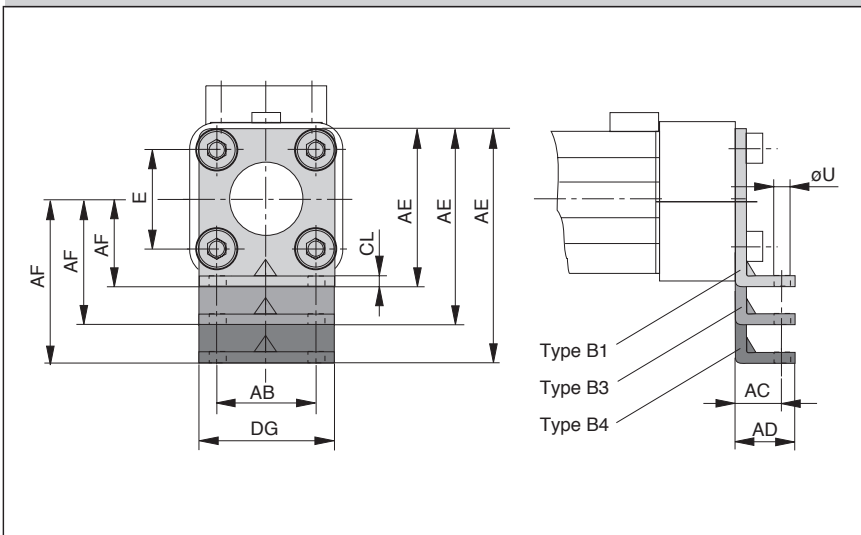

Dimension Table (mm)
– Dimensions AE and AF (Dependant on the mounting type)

Mount type	Dimensions AE for size			AF for size		
	25	32	50	25	32	50
A1	18	20	–	22	30	–
A2	33	34	–	37	44	–
A3	45	42	–	49	52	–
B1	42	55	–	22	30	–
B3	–	–	–	–	–	–
B4	80	85	–	60	60	–
C1	–	–	30	–	–	48
C2	–	–	39	–	–	57
C3	–	–	54	–	–	72
C4	–	–	77	–	–	95

Series OSP – E50: Type C

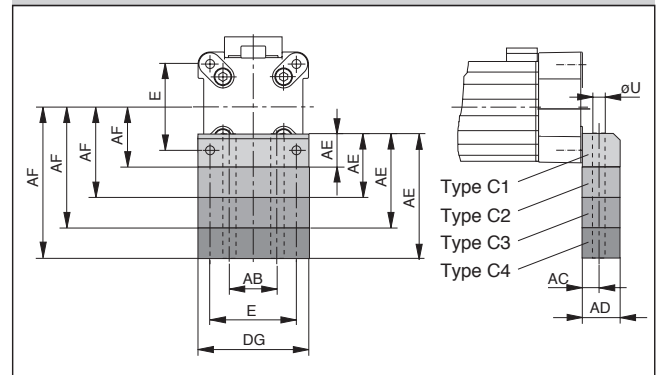

Dimension Table (mm)

Series	E	øU	AB	AC	AD	CL	D
OSP-E25	27	5.8	27	16	22	2.5	39
OSP-E32	36	6.6	36	18	26	3	50
OSP-E50	70	9	40	12.5	24	-	86

* see mounting instructions on page 96

Series OSP-E25, E32

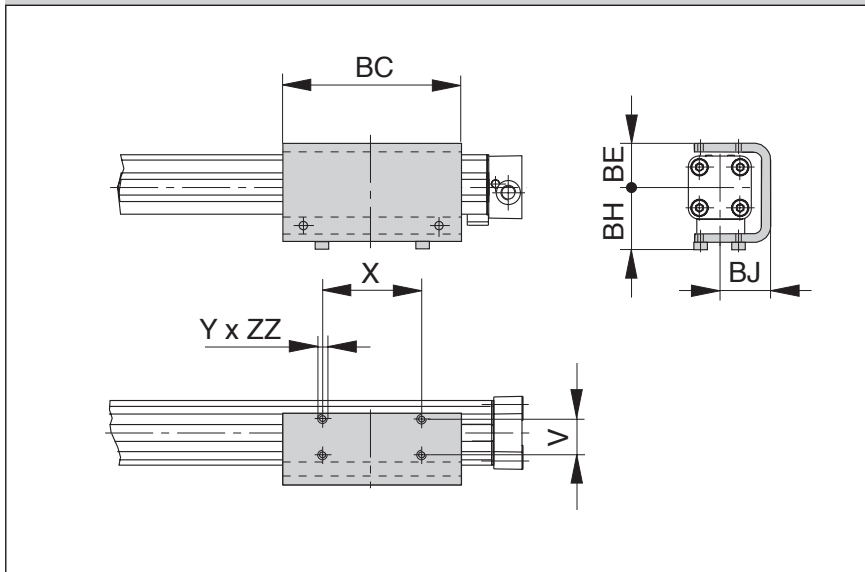

Series OSP-E50

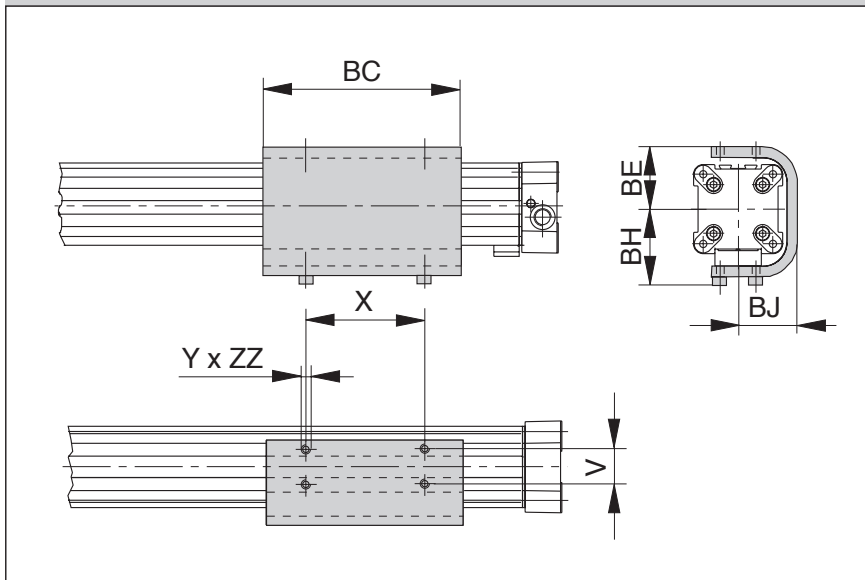

Dimension Table (mm)

Series	V	X	Y	BC	BE	BH	BJ	ZZ	Order No.
OSP-E25	25	65	M5	117	31	43	33.5	6	20037
OSP-E32	27	90	M6	150	38	51	39.5	6	20161
OSP-E50	27	110	M6	180	55	64	52	8	20166

The right to introduce technical modifications is reserved

Linear Drive Accessories

Inversion Mounting

Size 25, 32, 50



- For Linear Drive
- Series OSP-E Belt
 - Series OSP-E Screw

In dirty environments, or where there are special space problems, inversion of the cylinder is recommended. The inversion bracket transfers the driving force to the opposite side of the cylinder. The size and position of the mounting holes are the same as on the standard cylinder.

Stainless steel version on demand.

Please note:

Other components of the OSP system such as **mid-section supports**, **proximity switches** can still be mounted on the free side of the cylinder.

Important Note:

May be used in combination with Clevis Mounting, ref. page 92.



Linear Drive Accessories Adaptor Profile

Size 25, 32, 50



For Linear Drive

- Series OSP-E Belt
- Series OSP-E Screw
- Series OSP-E..BHD

Adaptor Profile OSP

- A universal attachment for mounting of additional items
- Solid material



Dimensions Series OSP-E

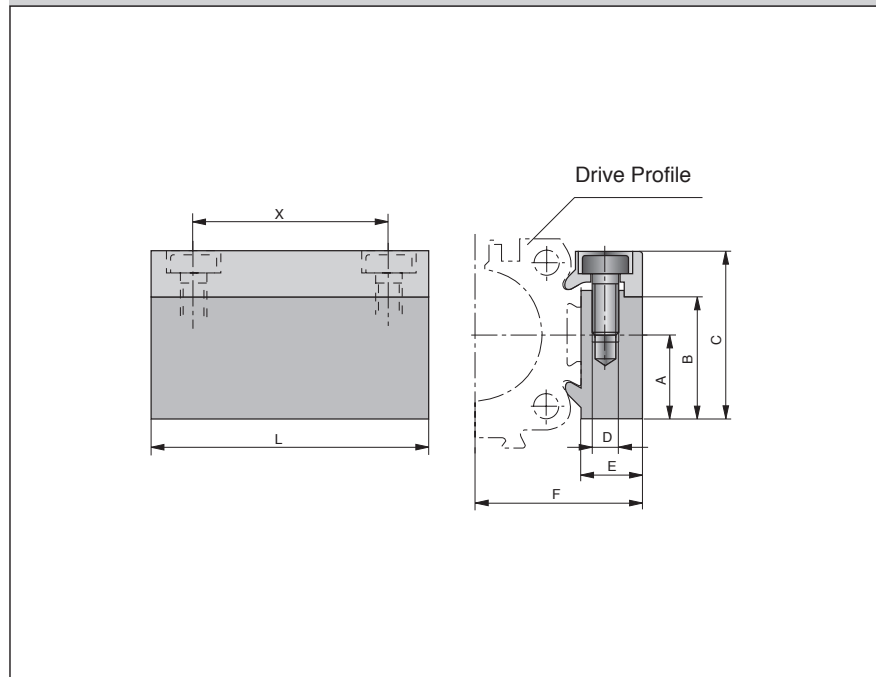

Dimensions Series OSP-E..BHD

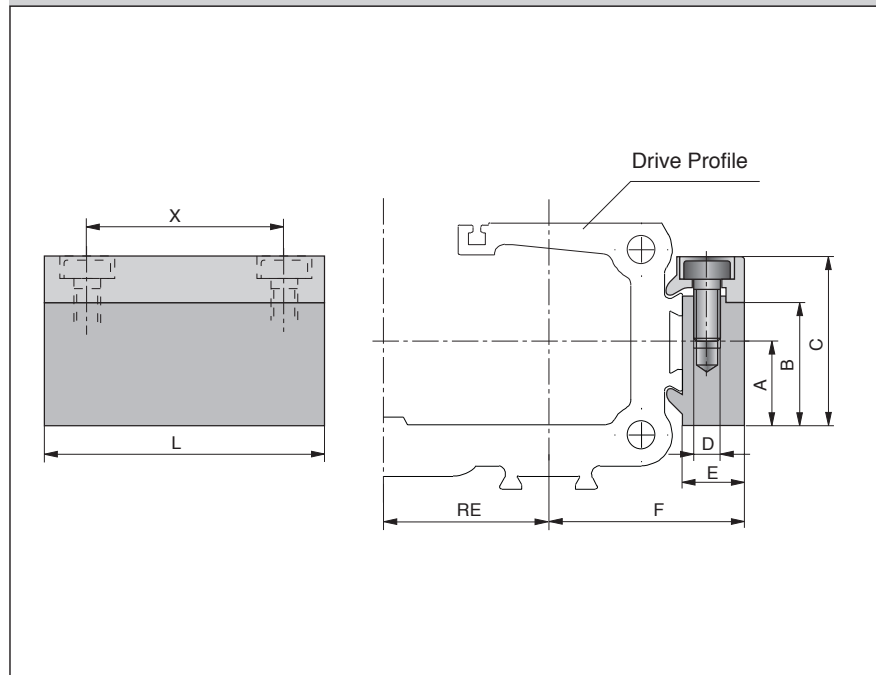

Dimension Table (mm)

Series	A	B	C	D	E	F	L	X	RE	Order No.	
										Standard	Stainless
OSP-E25	16	23	32	M5	10.5	30.5	50	36	26	20006	20186
OSP-E32	16	23	32	M5	10.5	36.5	50	36	32	20006	20186
OSP-E50	20	33	43	M6	14	52	80	65	44	20025	20267

The right to introduce technical modifications is reserved

Dimensions Series OSP-E

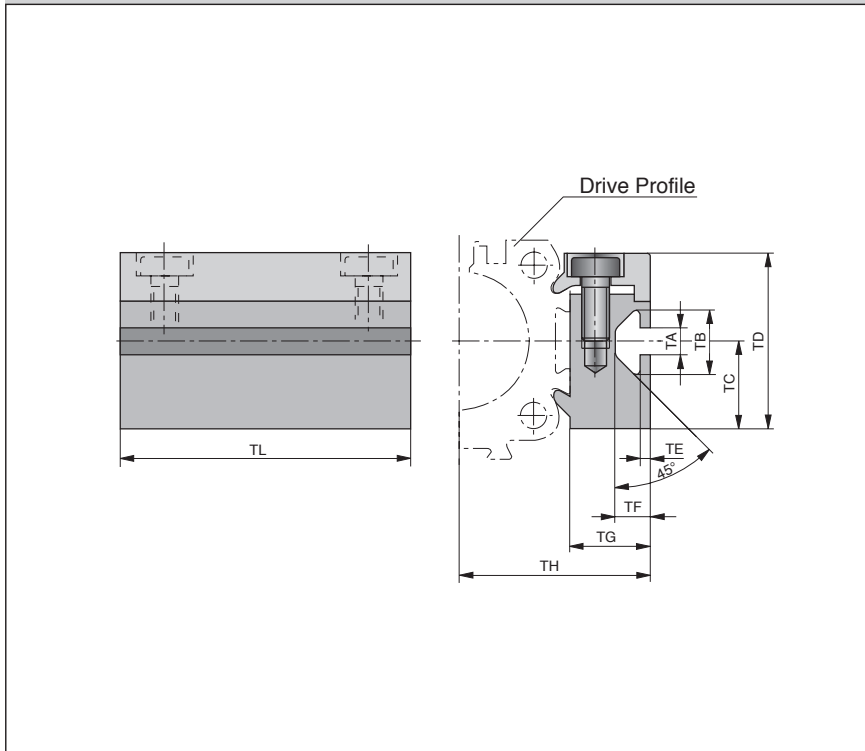

Linear Drive Accessories

T-Nut Profile

Size 25, 32, 50



- For Linear Drive
- Series OSP-E Belt
 - Series OSP-E Screw
 - Series OSP-E..BHD

T-Nut Profile OSP

- A universal attachment for mounting with standard T-Nuts

Dimensions Series OSP-E..BHD

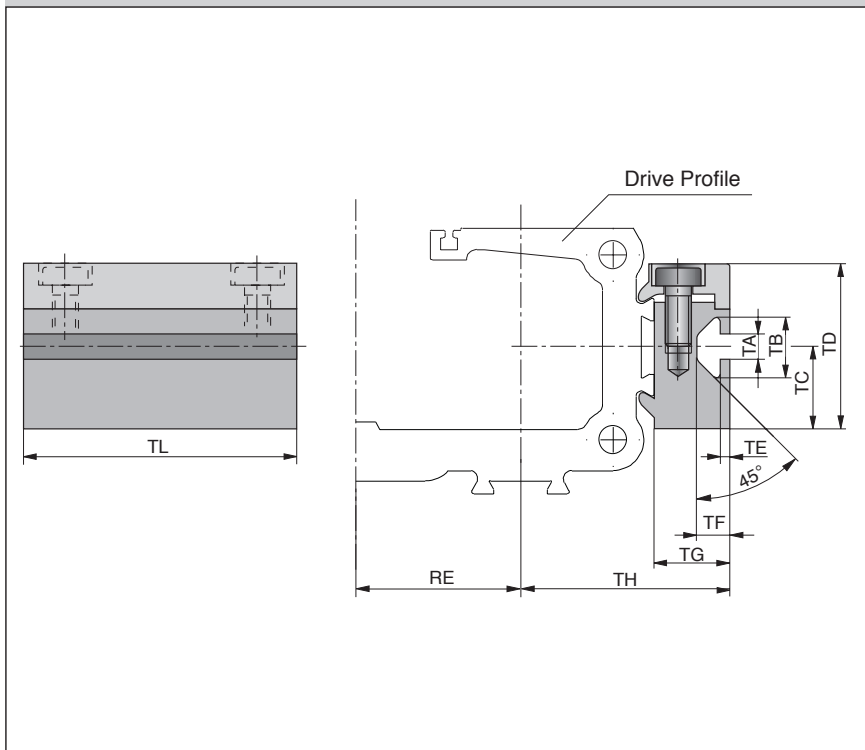

The right to introduce technical modifications is reserved

Dimension Table (mm)

Series	RE	TA	TB	TC	TD	TE	TF	TG	TH	TL	Order No.	
											Standard	Stainless
OSP-E25	26	5	11.5	16	32	1.8	6.4	14.5	34.5	50	20007	20187
OSP-E32	32	5	11.5	16	32	1.8	6.4	14.5	40.5	50	20007	20187
OSP-E50	44	8.2	20	20	43	4.5	12.3	20	58	80	20026	20268



Linear Drive Accessories

Profile Mountings

Size 25, 32, 50



For Linear Drive

- Series OSP-E Belt
- Series OSP-E Screw
- Series OSP-E..BHD

Material:

Anodized aluminum

Stainless steel version on demand.

The mountings are supplied in pairs.

Weight (mass) [kg]	
Type	Weight (mass) [kg] (pair)
MAE-25	0.3
MAE-32	0.4
MAE-50	0.8

Series OSP-E25 to E50, Type MAE-..

Series OSP-E..

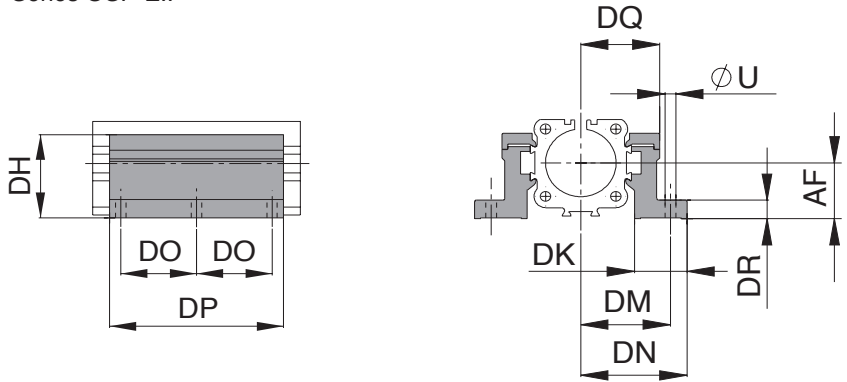

Series OSP-E..BHD

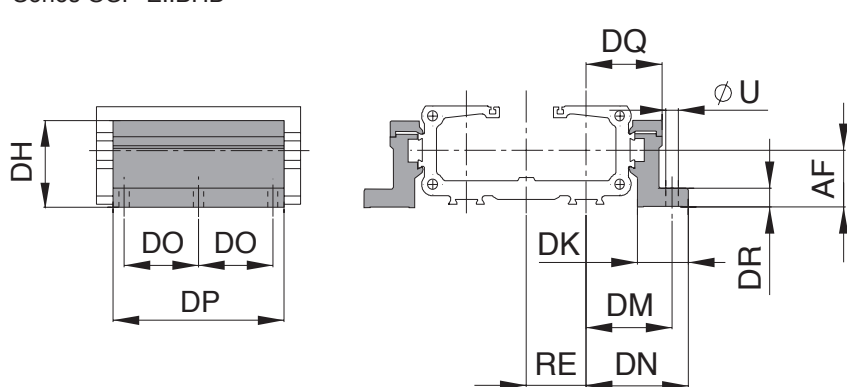

Dimension Table (mm)																				
Series	Type	R	U	AF	DF	DH	DK	DM	DN	DO	DP	DQ	DR	DT	EF	EM	EN	EQ	RE	Order No.
OSP-E25	MAE-25	M5	5.5	22	27	38	26	40	47.5	40	92	34.5	8	10	41.5	28.5	49	36	26	12278
OSP-E32	MAE-32	M5	5.5	30	33	46	27	46	54.5	40	92	40.5	10	10	48.5	35.5	57	43	32	12279
OSP-E50	MAE-50	M6	7	48	40	71	34	59	67	45	112	52	10	11	64	45	72	57	44	12280



The right to introduce technical modifications is reserved