

Linear Actuator with Toothed Belt Series OSP-E..B

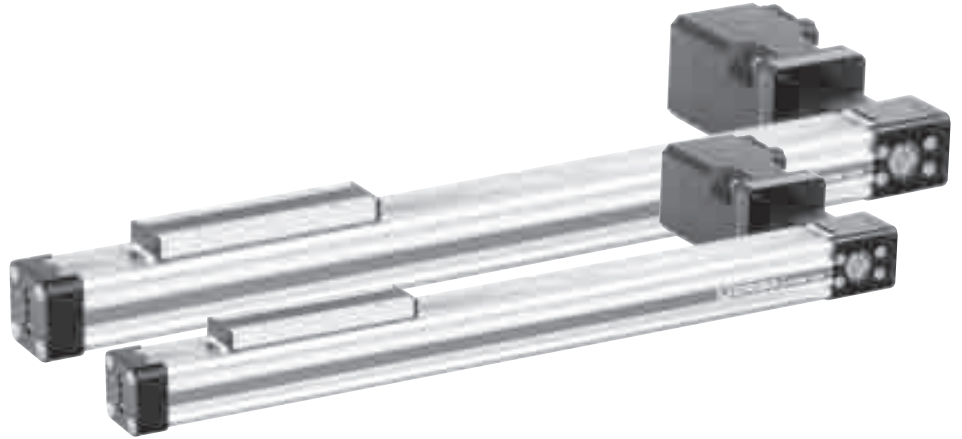

Contents

Description	Page
Overview	47-50
Technical Data	51-55
Dimensions	56

ELECTRIC LINEAR ACTUATOR FOR POINT-TO-POINT APPLICATIONS

A completely new generation of linear drives which can be integrated into any machine layout neatly and simply.

Linear Actuator with Toothed Belt

Advantages:

- Precise path and position control
- High speed operation
- Easy installation
- Low maintenance
- Ideal for precise point-to-point and reciprocating applications

Features:

- Integrated drive and guidance system
- Long available strokes
- Complete motor and control packages
- Diverse range of accessories and mountings
- Bi-parting and special options available

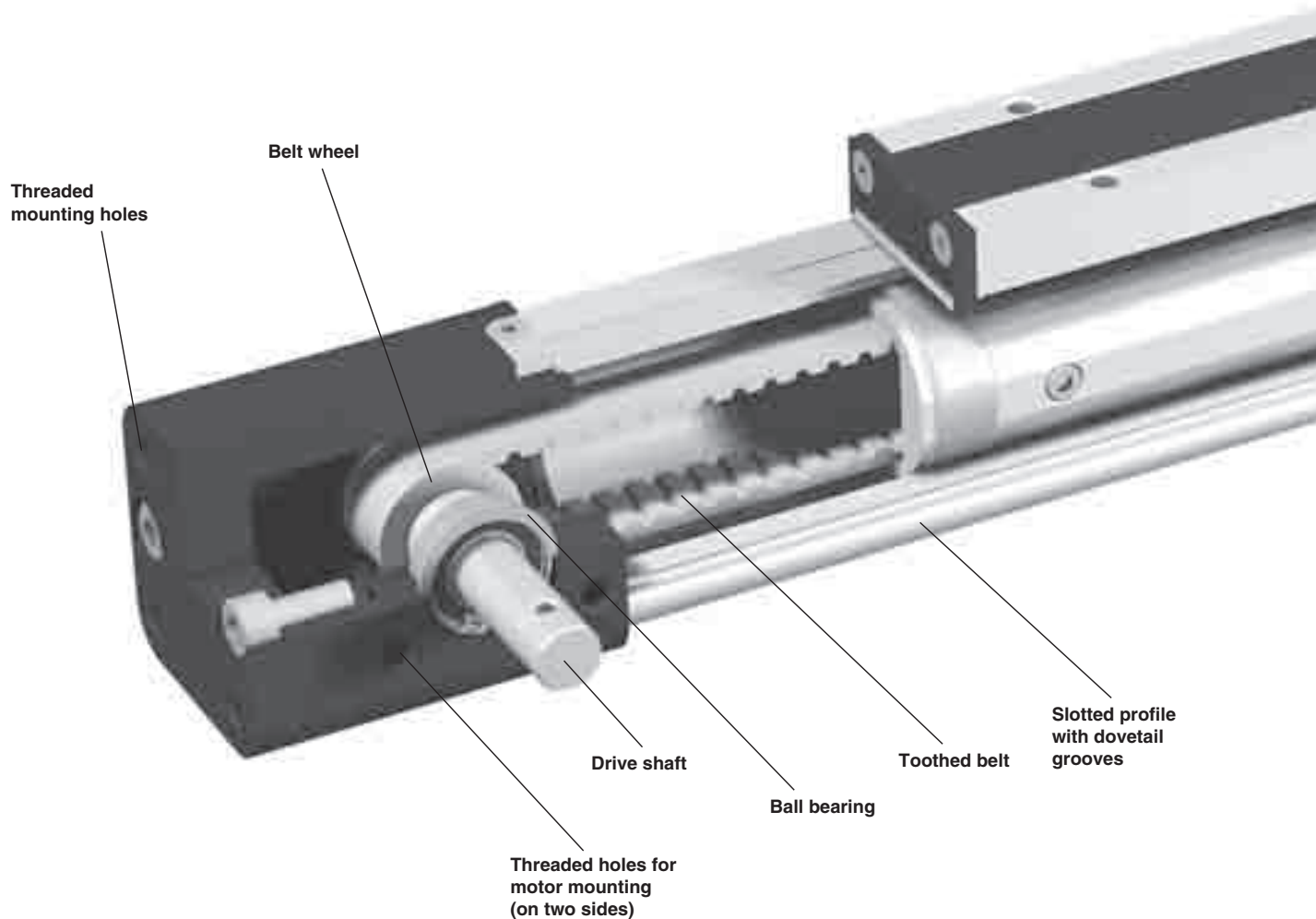

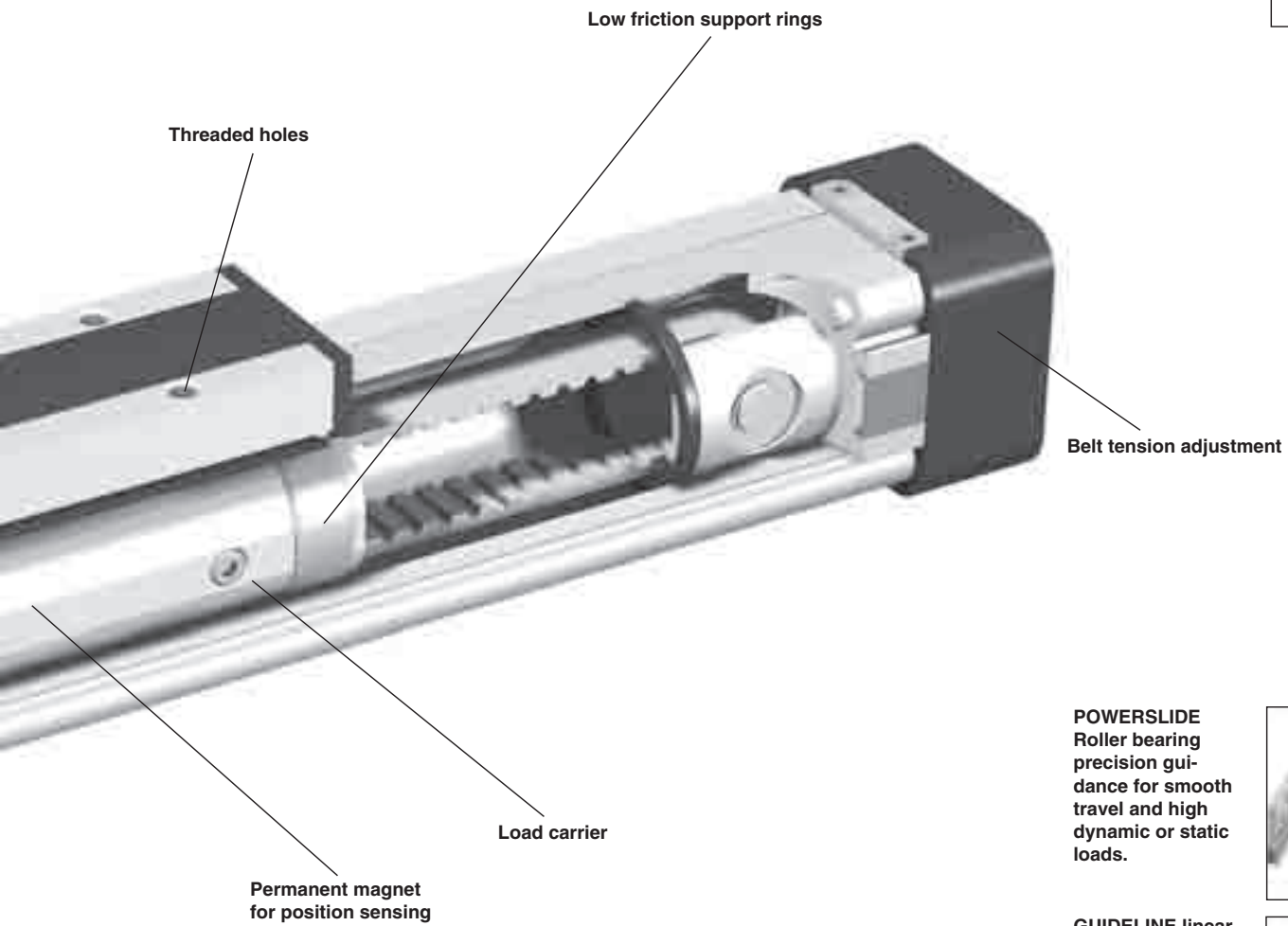

PROLINE
The compact aluminium roller guide for high loads and velocities.



POWERSLIDE
Roller bearing precision guidance for smooth travel and high dynamic or static loads.



GUIDELINE linear guides for heavy duty applications.



The dovetailed mounting rails of the new linear actuator expand its function into that of a universal system carrier. Modular system components are simply clamped on.

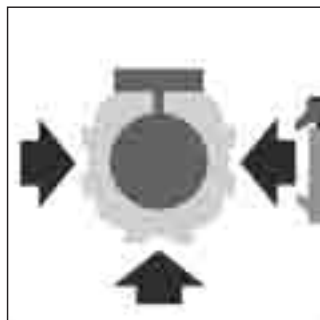

OPTIONS AND ACCESSORIES

SERIES OSP-E, BELT DRIVEN

STANDARD VERSIONS OSP-E..B

Standard carrier with integral guidance.
Dovetail profile for mounting of accessories and the actuator itself.

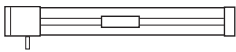
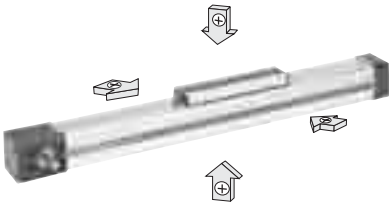

BASIC ACTUATOR OPTIONS

DRIVE SHAFT OPTIONS

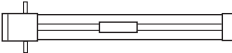
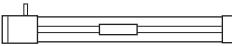

MOUNTINGS FOR OSP-E25 TO E50

CLEVIS MOUNTING

Page 68-69
Carrier mounting for driving loads supported by external linear guides.

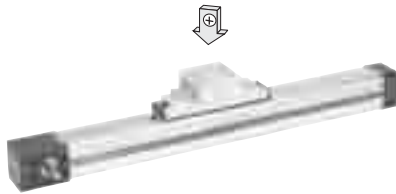

END CAP MOUNTING

Page 70
For end-mounting of the actuator



MID-SECTION SUPPORT

Page 71
For supporting long actuators or mounting the actuator on the dovetail grooves.



INVERSION MOUNTING

Page 75

The inversion mounting, mounted on the carrier, transfers the driving force to the opposite side, e.g. for dirty environments.

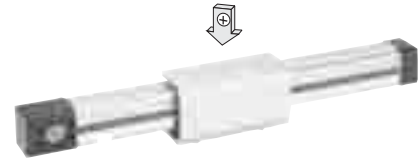

Characteristics			
Characteristics	Symbol	Unit	Description
General Features			
Type			Linear Actuator with Toothed Belt
Series			OSP-E..B
Mounting			See drawings
Ambient Temperature range	ϑ_{\min} ϑ_{\max}	°C °C	-30 +80
Weight (mass)		kg	See table
Installation			In any position
Material	Slotted profile		Extruded anodized aluminium
	Toothed belt		Steel-corded polyurethane
	Belt wheels		Aluminium
	Sealing band		Hardened stainless steel
	Screws, nuts		Zinc plated steel
	Mountings		Zinc plated steel and aluminium
Encapsulation class		IP	54

Weight (mass) kg and Inertia					
Series	At stroke 0 m	Weight (mass) kg]		Inertia [$\times 10^{-6}$ /kgm ²]	
		Add per metre stroke	Moving mass	At stroke 0 m	Add per metre
OSP-E25	0.9	1.6	0.25	25.3	6.6
OSP-E32	1.8	3.2	0.43	43.3	10
OSP-E50	5.3	6.3	1.08	312.2	45

Installation Instructions

Use the threaded holes in the end cap for mounting the linear actuator. See if mid-section supports are needed using the maximum allowable un-supported length graph on page 53.

At least one end cap must be secured to prevent axial sliding when mid-section support is used.

When the linear actuator is moving an externally guided load, the clevis mounting should be used (see page 68).

The linear actuators can be fitted with the standard carrier mounting facing in any direction.

To prevent contamination such as fluid ingress, the actuator should be fitted with its sealing band facing downwards.

The inversion mounting can be fitted to transfer the driving force to the opposite side (see page 75).

Maintenance

All moving parts are long-term lubricated for a normal operational environment. We recommend a check and lubrication of the linear actuator, and if necessary a change of the toothed belt and wear parts, after an operation time of 4 000 hours of operation or 3 000 km, depending on the type of application.

Start Up

The products in this datasheet should not be operated until the machine/ application in which they are used has passed necessary inspection.

Linear Actuator with Toothed Belt

Series OSP-E..B Size 25, 32, 50



Standard Versions:

- Standard carrier with integral guidance.
- Dovetail profile for mounting of accessories and the actuator itself.

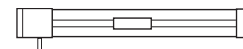

Special Versions:

- Position of Drive Shafts

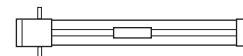
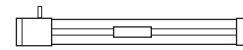

Sizing Performance Overview

Maximum Loadings

Sizing of Linear Actuator

The following steps are recommended for selection :

1. Required acceleration is shown in graphs on page 54.
2. Required torque is shown on page 55.
3. Check that maximum values in the adjacent charts are not exceeded.
4. Check max. allowable torque on drive shaft by using table T2. (Pay attention to note under table) If value is lower than required, overview the moving profile or select if possible a bigger unit.
5. Before sizing and specifying the motor, the average torque must be calculated using the cycle time of the application.
6. Check that the maximum allowable unsupported length is not exceeded (see on page 53).

Performance Overview

Characteristics	Unit	Description			
Size		OSP-E25B	OSP-E32B	OSP-E50B	
Max. speed	[m/s]	2	3	5	
Linear motion per revolution, drive shaft	[mm]	60	60	100	
Max. rpm. drive shaft	[min ⁻¹]	2 000	3 000	3 000	
Max. effective action force	< 1 m/s:	[N]	50	150	425
	1- 2 m/s:	[N]	50	120	375
F _A at speed	> 2 m/s:	[N]	–	100	300
No-load torque	[Nm]	0.4	0.5	0.6	
Max. acceleration/deceleration	[m/s ²]	10	10	10	
Repeatability	[mm/m]	±0.05	±0.05	±0.05	
Max. standard stroke length	[mm]	3000	5000	5000	

Maximum Allowable Torque on Drive Shaft Speed and Stroke

T2

OSP-E25B				OSP-E32B				OSP-E50B						
Speed [m/s]	Torque [Nm]	Stroke [m]	Torque [Nm]	Speed [m/s]	Torque [Nm]	Stroke [m]	Torque [Nm]	Speed [m/s]	Torque [Nm]	Stroke [m]	Torque [Nm]			
1	0.9	1	0.9	1	2.3	1	2.3	1	10.0	1	10.0			
2	0.9	2	0.9	2	2.0	2	2.3	2	9.5	2	10.0			
	3	0.9	3		1.8		3		3		3	9.0	3	9.0
3	0.9	3	3	1.8	3	3	2.3	4	8.0	4	7.0			
							4		2.3		4	7.5	5	6.0
							5		1.8		5	7.5	5	6.0

Important:

The maximum permissible moment on the drive shaft is the lowest value of the speed- or stroke-dependent moment value.

Example above: OSP-E32B-stroke 2 m, required speed 3 m/s;

From table T2: speed 3 m/s gives 1.8 Nm and stroke 2 m gives 2.3 Nm.

Max. torque for this application is 1.8 Nm.

Maximum Allowable Static Loadings

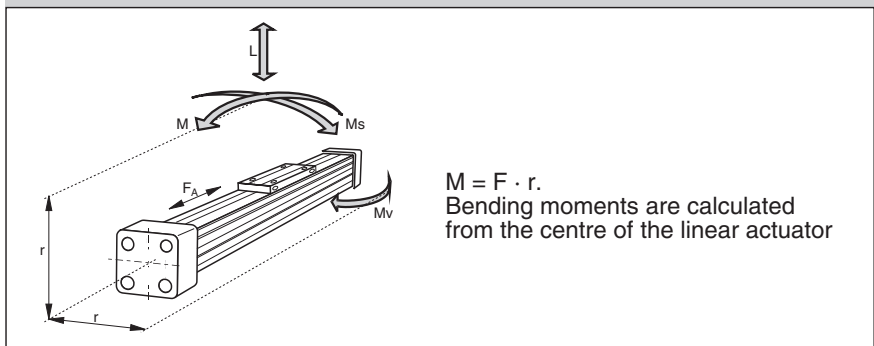

Size	Max. applied load L [N]	Max. moments [Nm]		
		M	M _s	M _v
OSP-E25B	160	12	2	8
OSP-E32B	300	25	8	16
OSP-E50B	850	80	16	32

Combined Loadings

If several forces and moments are applied to the linear actuator simultaneously, then the following equation must be fulfilled in addition to the maximum loadings stated beside.

$$\frac{L}{L(\max)} + \frac{M}{M(\max)} + \frac{M_s}{M_s(\max)} + \frac{M_v}{M_v(\max)} \leq 1$$

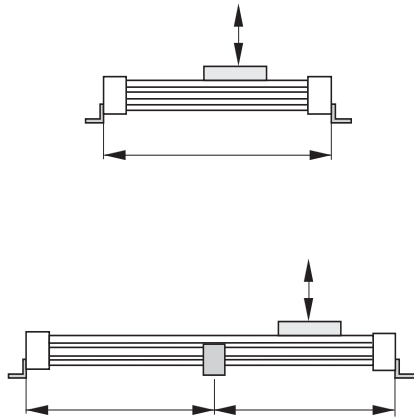

k = Maximum allowable distance between mountings/mid-section support for a given load (L)

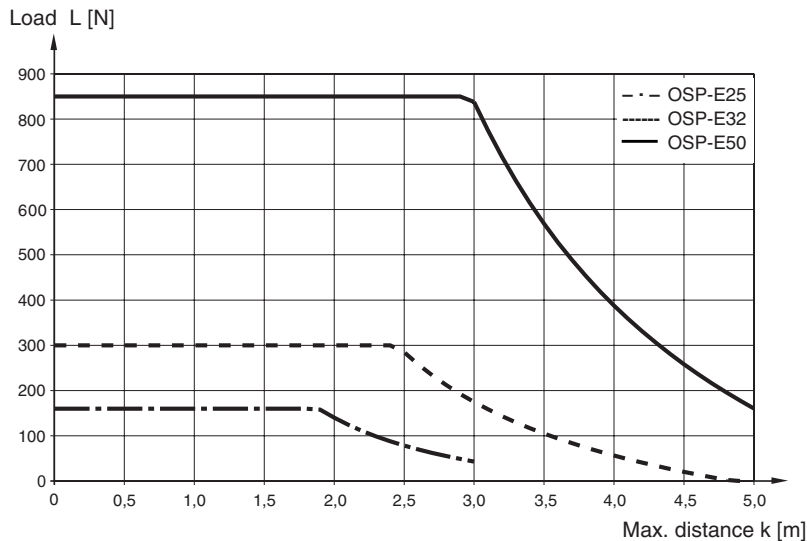

(Up to the curve in the above graph the deflection will be max. 0.2 % of distance k.)

Maximum Allowable Unsupported Length Stroke Length

Stroke Lengths

The stroke lengths of the linear actuators are available in multiples of 5 mm up to 5 m.
(OSP-E25: max. 3 m)

Other stroke lengths are available on request.

The end of stroke must not be used as a mechanical stop.

Allow an additional safety clearance at both ends equivalent to the linear movement of one revolution of the drive shaft.

The use of an AC motor with frequency converter normally requires a larger safety clearance than that required for servo systems.

For advise, please contact your local HOERBIGER-ORIGA technical support department.

When mechanical stops are required, external shock absorbers should be used (see separate catalogue).

Align the centre line of the shock absorber as closely as possible with the object's centre of gravity.

Mounting on the Drive Shaft

Do not expose the drive shaft to uncontrolled axial or radial forces when mounting coupler or belt wheel, a steadying block should be used.

Belt wheels

Minimum allowable number of teeth Z (AT5) at maximum applied torque.

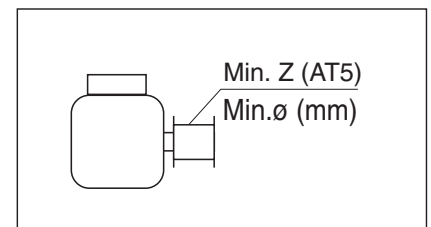

Size	Min. Z	Min. ø
OSP-E25B	24	38
OSP-E32B	24	38
OSP-E50B	36	57

Required Acceleration

Distance-Time Graph

Using the required travel distance and total time, the adjacent graphs show the required acceleration based on maximum speed.

The graphs assume that acceleration and deceleration are equal.

Please note that specifying non-essential high acceleration or short cycle time will result in an oversized motor.

Max. speed 1 m/s

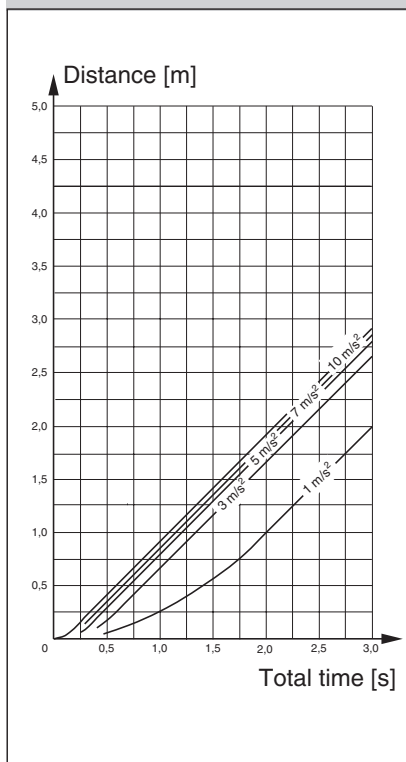

Max. speed 2 m/s

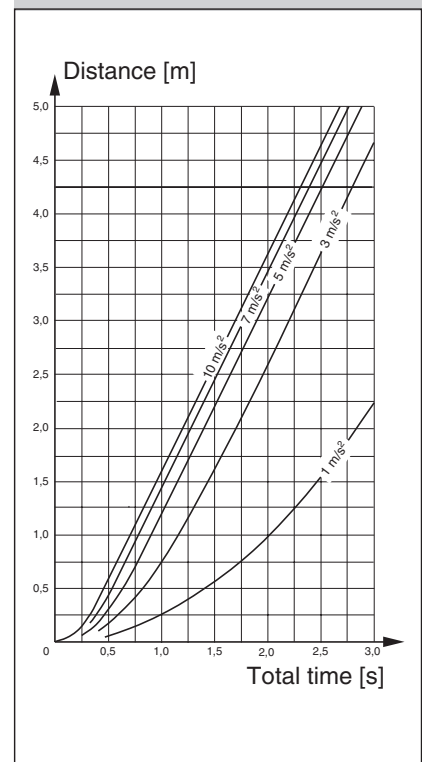

Max. speed 3 m/s

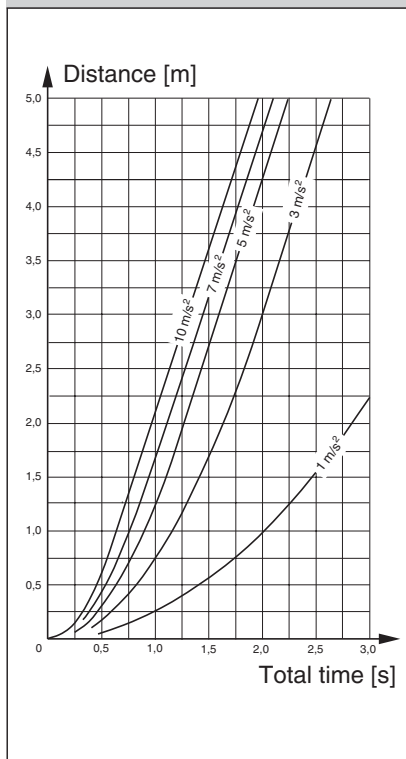

Max. speed 5 m/s

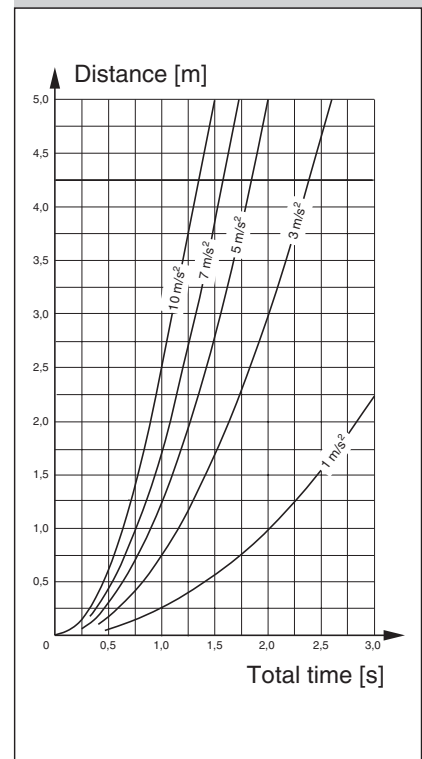

**Size OSP-E25,
Horizontal Application**

Torque M [Nm]

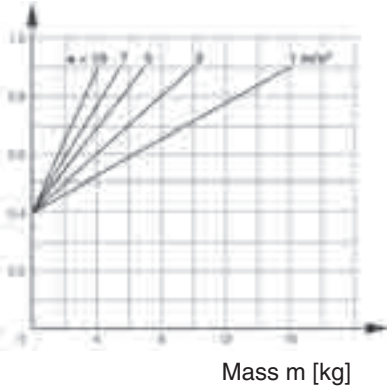

**Size OSP-E25,
Vertical Application**

Torque M [Nm]

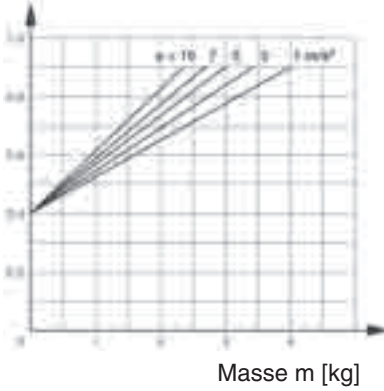

Required Torque

Using the known mass, the direction of the application and the required acceleration from the distance-time graphs, the linear actuator can be sized and the required torque is shown in the adjacent graphs. Mass in graphs = Load + moving mass of the linear actuator (according to the weight chart on page 51).

Please note:

When using an additional guide, please add the mass of the carriage to the total moving mass.

**Size OSP-E32,
Horizontal Application**

Torque M [Nm]

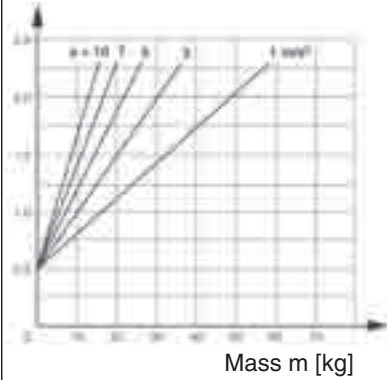

**Size OSP-E32,
Vertical Application**

Torque M [Nm]

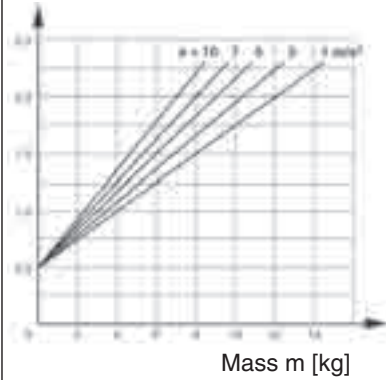

**Size OSP-E50,
Horizontal Application**

Torque M [Nm]

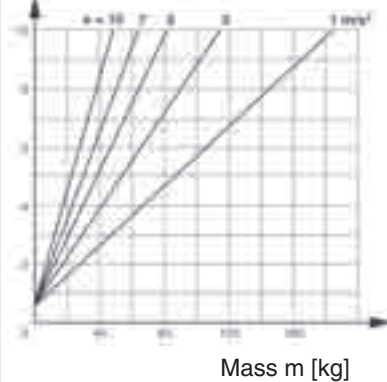

**Size OSP-E50,
Vertical Application**

Torque M [Nm]

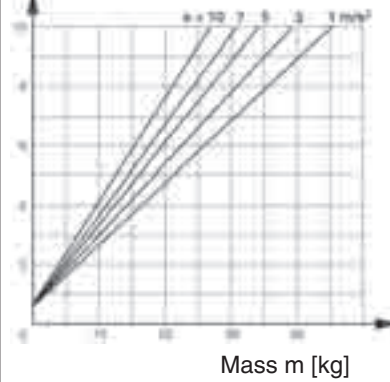

Belt Driven Linear Actuator - Basic Unit
Series OSP-E25B, -E32B, -E50B

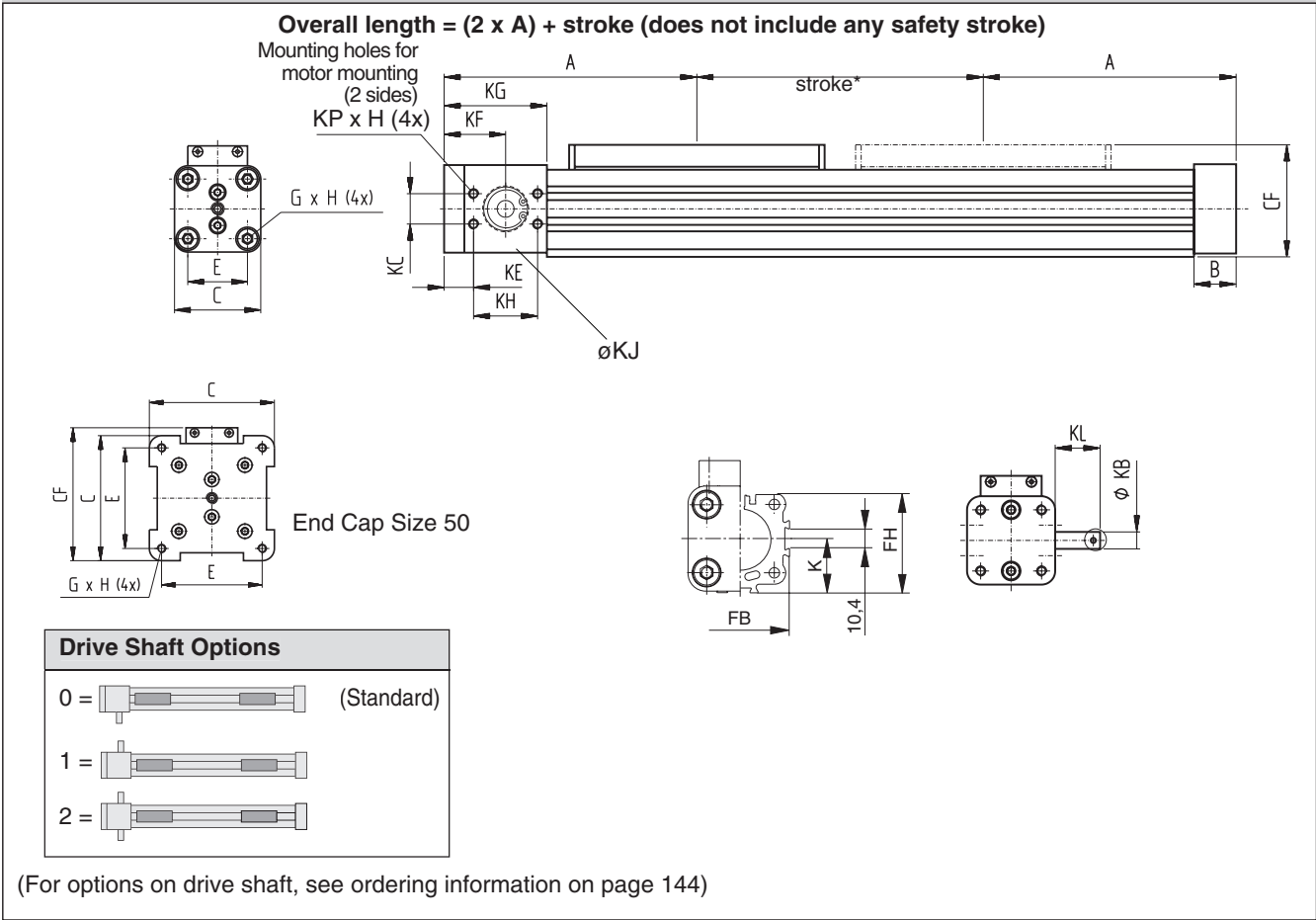

* The end of stroke must not be used as a mechanical stop. Add to both ends, a minimum extra length, corresponding to the linear motion per one revolution of the drive shaft. The use of AC motor with frequency converter drives normally requires a larger 'extra length' than that required for servo systems. For advise, please contact your local HOERBIGER-ORIGA technical support department.

When mechanical stops are required CONSULT FACTORY.

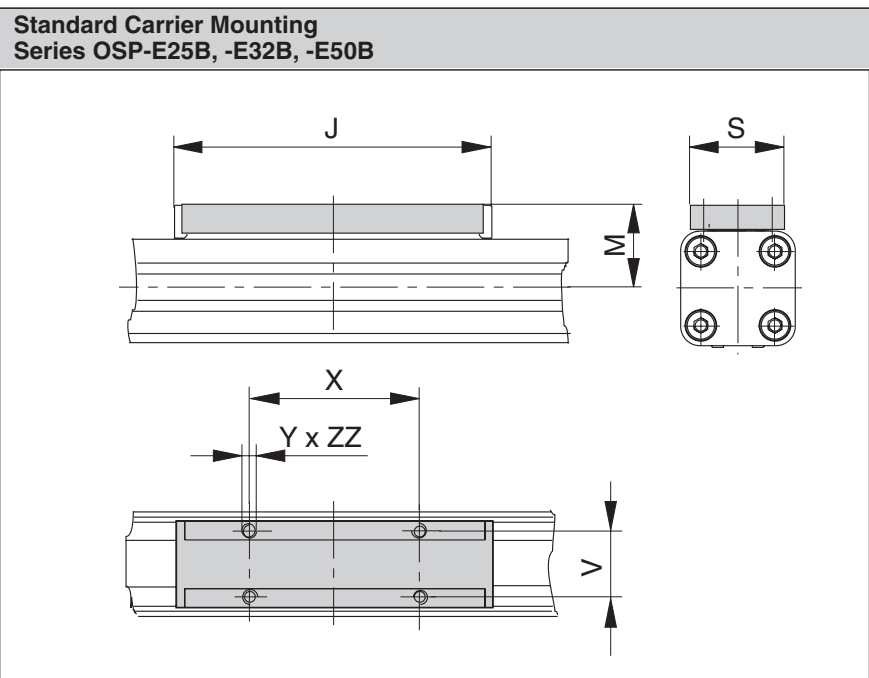

Dimension Table (mm)

Series	A	B	C	E	G	H	J	K	M	S	V	X	Y	CF	FB	FH	KB	KC	KE	KF	KG	KH	KJ	KL	KP	ZZ
OSP-E25B	125	22	41	27	M5	10	117	21.5	31	33	25	65	M5	52.5	40	39.5	10 ₆	15	22	37	57	30	19 ^{H7}	24	M5	8
OSP-E32B	150	25	52	36	M6	12	152	28.5	38	36	27	90	M6	66.5	52	51.7	10 ₆	18	17.5	36.5	61	38	26 ^{H7}	26	M6	10
OSP-E50B	200	25	87	70	M6	12	200	43	49	36	27	110	M6	92.5	76	77	16 _{h8}	32	23.5	48.5	85	50	40 ^{H7}	34	M8	10